

7 TONNE AXLE STANDS



Disclaimer:

The information in this document is to the best of our knowledge true and accurate, but all recommendations or suggestions are made without guarantee. Since the conditions of use are beyond their control, Tundra Industrial ® disclaim any liability for loss or damage suffered from the use of this data or suggestions. Tundra Industrial ® reserve the right to change product specifications and warranty statements without further notification. All images are for illustration purposes only.

1. SAFETY GUIDELINES

- 1.1 Please read the following guidelines carefully before using this equipment. This equipment must be kept clean and kept in good working order in order to ensure safe and effective operation. Inspect the equipment carefully before use and do not use if any defects are identified. Contact your nearest Tundra Industrial Dealer for further information on repairs and replacement parts.
- 1.2 The maximum load for this equipment is **7 Tonnes** per stand. Do not exceed this rated capacity.
- 1.3 Use only as specified by the manufacturer.
- 1.4 Use no more than a single pair of stands either on the front or rear of the vehicle. **Always use in pairs.**
- 1.5 No alterations or modifications shall be made to this product.
- 1.6 Use on a hard, level surface, e.g. concrete. Do not use on uneven ground or tarmacadam.
- 1.7 Securely chock wheels in contact with the ground. Before jacking and placing the stands, apply vehicle handbrake (put automatics in 'Park').
- 1.8 Make sure that each stand is securely located under a strong point on the vehicle; consult the vehicle manufacturer's handbook for guidance. Ensure that height adjust locking mechanism is fully located before applying any load to the axle stand.
- 1.9 Ensure that the load is located centrally on the saddle, and that the weight is directed through the vertical axis of the stand.
- 2.0 Exercise extra care when using with a three wheeled vehicle or a trailer. Refer to vehicle manufacturer's instructions.
- 2.1 Once vehicle is supported, ensure that the vehicle and stands are stable before starting work. Ensure that it is not possible for the vehicle to move before commencing any work.
- 2.2 Inspect stands before each use. DO NOT use if they show signs of damage. DO NOT use if it is suspected that they have been overloaded.
- 2.3 Before commencing any work or going beneath the vehicle, undertake a risk assessment. Ensure that a responsible person is aware of the work about to be undertaken.



WARNING:

No responsibility is accepted for incorrect use of this equipment. Incorrect use can result in damage to the equipment and danger to the user. Warranty will be void in the event of incorrect use. Hydraulic products are only repaired by Tundra Industrial authorised engineers. The warnings, cautions and instructions discussed in this instruction manual cannot cover all possible conditions and situations that may occur. It must be understood by the operator that common sense and caution are factors which cannot be built into this product, but must be supplied by the operator.

2. SPECIFICATIONS

Model Number	TUNAXSTD07
Maximum Load:	7 Tonne (14 Tonne Capacity Pair)
Minimum Height:	267mm
Maximum Height:	420mm
Weight (NW/GW):	14kg / 14.6kg

3. DESCRIPTION

These industrial axle stands are manufactured from heavy-duty steel for strength and durability. Features include:

- (2x) Heavy-duty 7 Tonne axle stands.
- Sturdy welded steel construction for superior safety and strength, which helps prevent distortion and twisting
- Large saddles for even load distribution
- Supplied with captive pin load support
- Suitable for use with forklifts and vehicles with low suspension
- Sold, and designed for use, in pairs

4. ASSEMBLY

Use the parts diagram on the next page as a reference to help you to assemble this equipment.

Insert the extension column into the base collar. Secure the extension columns at the required height with the support rods.

5. OPERATING INSTRUCTIONS

WARNING! Ensure you prepare vehicle and use jack according to Section 1 SAFETY GUIDELINES.

- Do not overload Axle stands beyond rated capacity. Overloading can cause damage to, or failure of, the Axle stands.
- POSITION LOAD ON CENTRE OF CRUTCH/SADDLE ONLY. ALWAYS USE STANDS IN PAIRS ON HARD LEVEL SURFACE CAPABLE OF SUSTAINING THE LOAD. USE OF STANDS ON OTHER THAN HARD LEVEL SURFACES CAN RESULT IN LOAD INSTABILITY AND POSSIBLE LOSS OF LOAD. DO NOT USE ON TARMACADAM.
- Failure to follow these instructions may result in damage to Axle stands, loss of load resulting IN property damage, SERIOUS personal injury OR LOSS OF LIFE.
- DANGER! GREAT CARE MUST BE TAKEN TO ENSURE YOU LOWER THE VEHICLE (OR OTHER LOAD) SLOWLY AND CAREFULLY ONTO THE CENTRES OF THE CRUTCH/SADDLE OF THE AXLE STANDS (See diagram RIGHT).

6. PARTS DIAGRAM

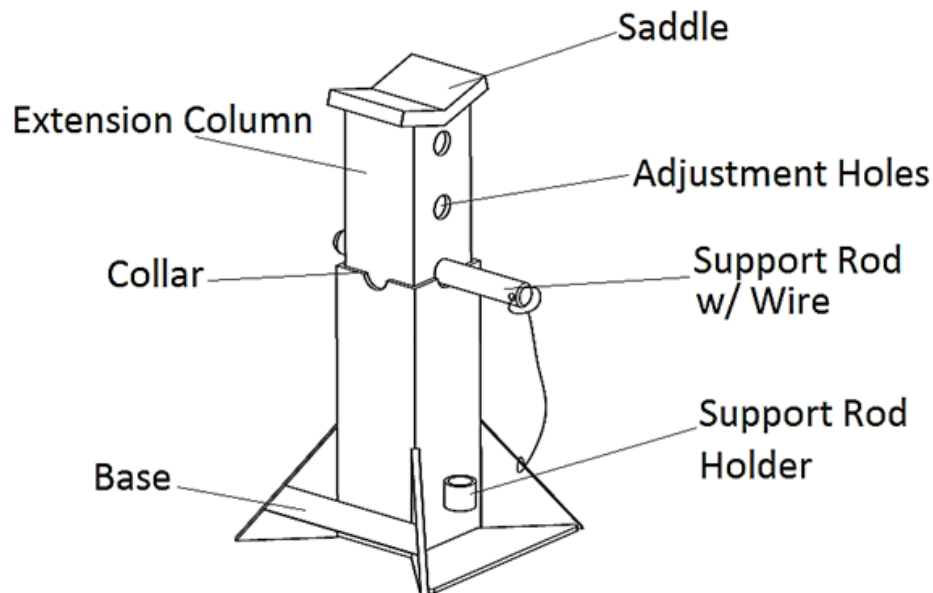

7. MAINTENANCE

- Before each use, check that stands and stand welds are not cracked and that there are no missing or damaged parts.
- Only apply grease to the locking handle pivot point of the stand and ensure all excess grease is wiped away before stand is used.
- If rust appears, sand away the rusted area and cover with appropriate utility paint.
- Please note that there are no replacement parts available for this product.
- Any suspect axle stands must be removed from service immediately
- Due to the potential hazards associated with stands, do not misuse, or make any modification to, the stands or components
- It is the responsibility of the owner to ensure that the operator has read these instructions together with the safety features on the side of the stand and that the operator is aware of the stand uses and limitations.



USER MANUAL

TUNAXSTD07

LIMITED WARRANTY STATEMENT

Tundra Industrial warrants its customers that its products will be free of defects in workmanship or material.

Tundra Industrial shall, upon suitable notification, correct any defects, by repair or replacement, of any parts or components of this product that are determined by Tundra Industrial to be faulty or defective.

This warranty is void if the equipment has been subjected to improper installation, storage, alteration, abnormal operations, improper care, unauthorised service or repair.

Warranty Period

Tundra Industrial will assume both the parts and labour expense of correcting defects during the stated warranty periods below. All warranty periods start from the date of purchase from an authorised Tundra Industrial dealer. If proof of purchase is not available from the end user, then the date of purchase will be deemed to be 3 months after the initial sale to the distributor.

1 Year

- Tundra Industrial 7 Tonne Axle Stands - [TUNAXSTD07]

90 Days

- All replacement parts purchased outside of the warranty period

Important: All parts used in the repair or replacement of warranty covered equipment will be subject to a minimum of 90 days cover or the remaining duration of the warranty period from the original date of purchase.

Warranty Registration / Activation

You can register and activate your warranty by visiting the Jefferson Tools website using the following address: www.jeffersonstools.com/warranty and completing the online form. Online warranty registration is recommended as it eliminates the need to provide proof of purchase should a warranty claim be necessary.

Warranty Repair

Should Tundra Industrial confirm the existence of any defect covered by this warranty the defect will be corrected by repair or replacement at an authorized Tundra Industrial dealer or repair centre.

Packaging & Freight Costs

The customer is responsible for the packaging of the equipment and making it ready for collection. Tundra Industrial will arrange collection and transportation of any equipment returned under warranty. Upon inspection of the equipment, if no defect can be found or the equipment is not covered under the terms of the Tundra Industrial warranty, the customer will be liable for any labour and return transportation costs incurred. These costs will be agreed with the customer before the equipment is returned.

Warranty Limitations

Tundra Industrial will not accept responsibility or liability for repairs made by unauthorised technicians or engineers. Tundra Industrial's liability under this warranty will not exceed the cost of correcting the defect of the Tundra Industrial products. Tundra Industrial will not be liable for incidental or consequential damages (such as loss of business or hire of substitute equipment etc..) caused by the defect or the time involved to correct the defect. This written warranty is the only express warranty provided by Tundra Industrial with respect to its products.

Any warranties of merchantability are limited to the duration of this limited warranty for the equipment involved. Tundra Industrial is not responsible for cable wear due to flexing and abrasion. The end user is responsible for routine inspection of cables for possible wear and to correct any issues prior to cable failure.

Claiming Warranty Coverage

The end user must contact Tundra Industrial (Tel: **+44 (0) 1244 646 048**) or their nearest authorised Tundra Industrial dealer where final determination of the warranty coverage can be ascertained.

Step 1 - Reporting the Defect

Online Method:

- Visit the website www.jeffersonstools.com/warranty and complete the Warranty Returns form. You can complete the form online and submit it to us directly or download the form to print out and return by post.

Telephone Method:

Contact your Tundra Industrial dealer or sales representative with the following information:

- Model number
- Serial number (usually located on the specification plate)
- Date of purchase

A Warranty Returns form will be sent to you for completion and return by post or fax, together with details of your nearest authorised Tundra Industrial repair centre. On receipt of this form Tundra Industrial will arrange to collect the equipment from you at the earliest convenience.

Step 2 - Returning the Equipment

It is the customer's responsibility to ensure that the equipment is appropriately and securely packaged for collection. Please ensure that you include a copy of your proof of purchase. Please note that Tundra Industrial cannot assume any responsibility for any damage incurred to equipment during transit. Any claims against a third party courier will be dealt with under the terms & conditions of their road haulage association directives.

Step 3 - Assessment and Repair

On receipt, the equipment will be assessed by an authorised Tundra Industrial engineer and it will be determined if the equipment is defective and in need of repair and any repairs needed are covered by the warranty policy. In order to qualify for warranty cover all equipment presented must have been used, serviced and maintained as instructed in the user manual.

Where repair is not covered by the warranty a quotation for repair, labour costs and return delivery will be sent to the customer (normally within 7 working days). **Note:** If the repair quotation is not accepted Tundra Industrial will invoice 1 hour labour time at £30 per hour plus return carriage costs (plus VAT).

In cases where no fault can be found with the equipment, or, if incorrect operation of the equipment is identified as the cause of the problem, a minimum of 1 hour labour at £30 per hour plus carriage costs will be required before the equipment will be despatched back to the customer.

Any equipment repaired or replaced under warranty will normally be ready for shipment back to the customer within 7 working days upon receipt of the equipment at an authorised Tundra Industrial Repair centre (subject to part availability). Where parts are not immediately available Tundra Industrial will contact you with a revised date for completion of the repair.

General Warranty Enquiries

For any further information relating to Tundra Industrial warranty cover please call **+44 (0) 1244 646 048**.

