



JEFWLT20WTEL-230

**20W TELESCOPIC LED WORKLIGHT
1400 LUMENS • 230V**



General Safety Guidelines

Please read all safety guidelines and instructions to ensure the safe use of this product. Failure to read all the safety guidelines can result in serious injury. Keep this user guide in a safe place for later reference.

Work Area

Ensure work area is kept clear, uncluttered and well-lit to reduce the risk of accidents

Electrical Safety

Do not carry this equipment using the electric cord. Do not pull the cord to disconnect from mains power supply.

Ensure that the cord is kept away from heat, moisture, moving parts and sharp edges. Check plug and cable are in good condition before use. Ensure the correct fuse is fitted and that input supply corresponds with that specified for this equipment. Do not modify the plug in any way.

If the equipment is being used in a damp environment ensure that a residual current device (RCD) is used to protect the supply and reduce the risk of electrical shock.

In the event of fire use a CO2/dry chemical extinguisher.

Identification

1	Epistar Led Chip Panel
2	Lamp Housing
3.	Telescopic Stand
4.	Folding Tripod Legs

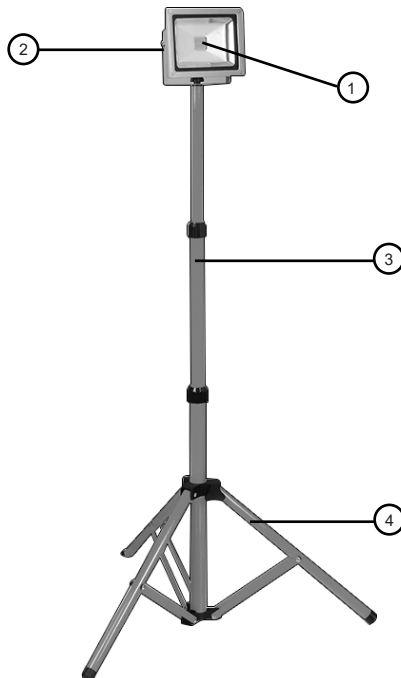

Specifications

Voltage:	230V
Input Power / Chip:	20W / 30mil Epistar LED Chip
Luminosity:	1400 Lumens
Colour Temperature:	6500k
Cable / Plug:	5M / 3A Plug
Ingress Protection (Housing):	IP65

Assembly

1. Attach the lamp head to the bracket by threading a washer on each of the angle fixing bolts.
2. Insert the bolts through the holes on each side of the bracket then into the side holes located on the lamp head brackets.
3. Hand tighten the bolts until fixed firmly.
4. Attach the lamp head assembly to the stand and thread the remaining bolt through the threaded hole in the stand and tighten up by hand until fixed firmly.

Handling & Storage

- Do not submerge this equipment in liquids
- Avoid pointing the light source directly at the eyes
- Check equipment for wear or damage before use
- Do not modify the equipment or use for purposes other than those it was designed
- Store in a cool dry environment, keep away from children

Limited Warranty Statement

Jefferson Professional Tools & Equipment, or hereafter "Jefferson" warrants its customers that its products will be free of defects in workmanship or material. Jefferson shall, upon suitable notification, correct any defects, by repair or replacement, of any parts or components of this product that are determined by Jefferson to be faulty or defective.

This warranty is void if the equipment has been subjected to improper installation, storage, alteration, abnormal operations, improper care, unauthorised service or repair.

Warranty Period

Jefferson will assume both the parts and labour expense of correcting defects during the stated warranty periods below.

All warranty periods start from the date of purchase from an authorised Jefferson dealer. If proof of purchase is unavailable from the end user, then the date of purchase will be deemed to be 3 months after the initial sale to the distributor.

1 Year:

- Jefferson 20W Telescopic LED Worklight 230V (*JEFWLT20WTEL-230*)

90 Days:

- All replacement parts purchased outside of the warranty period

Important: *All parts used in the repair or replacement of warranty covered equipment will be subject to a minimum of 90 days cover or the remaining duration of the warranty period from the original date of purchase.*

Warranty Registration / Activation

You can register and activate your warranty by visiting the Jefferson Tools website using the following address: www.jeffersonstools.com/warranty and completing the online form.

Online warranty registration is recommended as it eliminates the need to provide proof of purchase should a warranty claim be necessary.

Warranty Repair

Should Jefferson confirm the existence of any defect covered by this warranty the defect will be corrected by repair or replacement at an authorized Jefferson dealer or repair centre.

Packaging & Freight Costs

The customer is responsible for the packaging of the equipment and making it ready for collection. Jefferson will arrange collection and transportation of any equipment returned under warranty.

Important: *All equipment returned under warranty must be accompanied by a proof of purchase*

Upon inspection of the equipment, if no defect can be found or the equipment is not covered under the terms of the Jefferson warranty, the customer will be liable for any labour and return transportation costs incurred.

These costs will be agreed with the customer before the machine is returned.

Warranty Limitations

Jefferson will not accept responsibility or liability for repairs made by unauthorised technicians or engineers. Jefferson's liability under this warranty will not exceed the cost of correcting the defect of the Jefferson products.

Jefferson will not be liable for incidental or consequential damages (such as loss of business or hire of substitute equipment etc.) caused by the defect or the time involved to correct the defect. This written warranty is the only express warranty provided by Jefferson with respect to its products.

Any warranties of merchantability are limited to the duration of this limited warranty for the equipment involved.

Jefferson is not responsible for cable wear due to flexing and abrasion. The end user is responsible for routine inspection of cables for possible wear and to correct any issues prior to cable failure.

Claiming Warranty Coverage

The end user must contact Jefferson Professional Tools & Equipment (Tel: +44 (0) 1244 646 048) or their nearest authorised Jefferson dealer where final determination of the warranty coverage can be ascertained.

Step 1 - Reporting the Defect

Online Method:

- Visit our website www.jeffersonstools.com/warranty and complete the Warranty Returns form. You can complete the form online and submit it to us directly or download the form to print out and return by post.

Telephone Method:

Contact your Jefferson dealer or sales representative with the following information:

- Model number
- Serial number (usually located on the specification plate)
- Date of purchase

A Warranty Returns form will be sent to you for completion and return by post or fax, together with details of your nearest authorised Jefferson repair centre. On receipt of this form Jefferson will arrange to collect the equipment from you at the earliest convenience.

Step 2 - Returning the Equipment

It is the customer's responsibility to ensure that the equipment is appropriately and securely packaged for collection. Please ensure that you include a copy of your proof of purchase. Please note that Jefferson cannot assume any responsibility for any damage incurred to equipment during transit. Any claims against a third party courier will be dealt with under the terms & conditions of their road haulage association directives.

Step 3 - Assessment and Repair

On receipt, the equipment will be assessed by an authorised Jefferson engineer and it will be determined if the equipment is defective and in need of repair and any repairs needed are covered by the warranty policy. In order to qualify for warranty cover all equipment presented must have been used, serviced and maintained as instructed in the user manual.

Where repair is not covered by the warranty a quotation for repair, labour costs and return delivery will be sent to the customer (normally within 7 working days).

Note: If the repair quotation is not accepted Jefferson Professional Tools & Equipment will invoice 1 hour labour time at £30 per hour plus return carriage costs (plus VAT).

In cases where no fault can be found with the equipment, or, if incorrect operation of the equipment is identified as the cause of the problem, a minimum of 1 hour labour at £30 per hour plus carriage costs will be required before the equipment will be despatched back to the customer.

Any equipment repaired or replaced under warranty will normally be ready for shipment back to the customer within 7 working days upon receipt of the equipment at an authorised Jefferson Repair centre (subject to part availability). Where parts are not immediately available Jefferson will contact you with a revised date for completion of the repair.

For any further information relating to Jefferson warranty cover please call +44 (0) 1244 646 048 or send your enquiry via email to warranty@jeffersonstools.com.

EC Declaration of Conformity

We, Jefferson Professional Tools & Equipment, as the authorised European Community representative of the manufacturer, declare that the following equipment conforms to the requirements of the following Directives:

20011/65/EU	RoHS
2014/30/EU	Electromagnetic Compatibility (EMC)
2014/35/EU	Low Voltage Directive

Equipment Category: LED Lighting
Product Name: 20W TELESCOPIC LED WORKLIGHT - 1400 LUMENS • 230V
Model: JEFWLT20WTEL-230

Signed by: Stephen McIntyre
Position in the company: Operations Director
Date: 20 June 2020



Technical file holder's address as shown below:

Name and address of manufacturer or authorised representative:

IMPORTANT! SAFETY FIRST!

Before attempting to use this product please read all the safety precautions and operating instructions outlined in this manual to reduce the risk of fire, electric shock and personal injury.

Jefferson Tools, Herons Way, Chester Business Park, Chester, United Kingdom, CH4 9QR
Tel. +44 (0)1244 646 048 Email: sales@jeffersonstools.com

www.jeffersonstools.com