

Auto Darkening Welding Helmet

JEFWELHT5TP



CE

User Manual

V2.1

www.jeffersonstools.com

Specification

• Viewing Area	98mm x 55mm (3.86" x 2.17")	• Switching Time Light to Dark	1/20000s (0.00005s)
• Cartridge Size	110 x 90 x 9mm (4.33" x 3.54" x 0.35")	• Switching Time Dark to Light	0.3s - 0.9s
• UV / IR Protection	Permanent Shade DIN16	• Operating Temperature	-5°C to + 55°C (23°F to 131°F)
• Light State	DIN Shade 4	• Storage Temperature	-20°C to + 70°C (-4°F to 158°F)
• Dark State	From DIN9 to DIN13 (Variable)	• Function Modes	Grinding Mode Welding Mode
• Power Supply	Solar cells, with built in Lithium battery	• Helmet Material	Hi Impact Polyamide Nylon EN 175:1997 [B]
• Power On / Off	Fully automatic	• Net Weight	470g
• ADF	EN 379 - 1/1/1/2	• Minimum Amperage	40 Amps



Note: This product is manufactured to conform with the latest manufacturing and safety standards.



IMPORTANT: PLEASE READ THESE INSTRUCTIONS CAREFULLY. NOTE THE SAFE OPERATIONAL REQUIREMENTS, WARNINGS & CAUTIONS. USE THE PRODUCT CORRECTLY AND WITH CARE FOR THE PURPOSE FOR WHICH IT IS INTENDED. FAILURE TO DO SO MAY CAUSE DAMAGE AND/OR PERSONAL INJURY AND WILL INVALIDATE THE WARRANTY. PLEASE KEEP INSTRUCTIONS SAFE FOR FUTURE USE.

1. Before Welding

- 1) Ensure that the filter, front cover lens, inside cover lens and four optical sensors are clean and secure.
- 2) Inspect all operating parts before use for signs of wear or damage. Any scratched, cracked or pitted parts should be replaced immediately before use to avoid severe personal injury.
- 3) Ensure that the position of the headband is adjusted to fit comfortably and safely. The helmet should be seated as low as possible on the head and close to the face.
- 4) Select the correct DIN Shade setting for your application see table below:

2. DIN Shade Settings

The shade number can be set manually between 9-13. Check the Shade Guide Table below to determine the proper shade number for your application. Select a shade number by turning the shade knob until the arrow points to the required setting:

Process	Arc Current (Amperes)																						
	0.5	1	2.5	5	10	15	20	30	40	60	80	100	125	150	175	200	225	250	275	300	350	400	450
SMAW						9	10	11			12			13			14						
MIG (Heavy)									10	11		12			13			14					
MIG (Light)									10	11		12		13		14		15					
TIG, GTAW				9	10	11			12		13			14									
MAG/CO2								10	11	12	13			14		15							
SAW											10	11	12	13	14	15							
PAC									11		12		13										
PAW				8	9	10	11	12		13		14			15								

3. Operation & Safety



WARNING: IF YOU ENCOUNTER ANY PROBLEMS WITH THE HELMET BEFORE OR DURING USE IT IS IMPORTANT THAT YOU DO NOT CONTINUE WITH THE WELDING PROCESS. IF THE FILTER FAILS TO DARKEN CORRECTLY, FLASHES OR IS UNABLE TO ATTAIN THE APPROPRIATE SHADE TO PROTECT YOUR EYES YOU SHOULD STOP IMMEDIATELY AND CONTACT YOUR JEFFERSON DEALER OR SUPPLIER.

3.1 Welding Protection

- Ensure that the helmet is not used in conditions where welding spatter is more than 43g and exceeding 120m/s.
- The helmet is manufactured to DIN BS EN175:1997 (Impact Level B) please ensure that the appropriate protective clothing is worn to protect any other parts of the body exposed during the welding process.

3.2 Sensitivity, Mode and DIN Shade Settings

- Before you start welding adjust the Mode, Sensitivity and DIN Shade to the appropriate settings for the welding process (see **Fig1a** & **Fig1b**) and arc amperage (see table on page 2).
- Continue to adjust the DIN shade settings to attain the appropriate brightness to allow you to see the welding molten pool and the welding spot without glare.

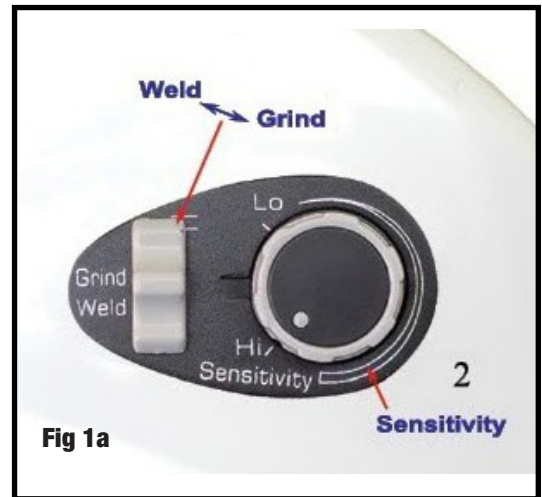

3.3 DIN Shade Delay Setting

It is important that the correct delay setting is used for your welding process to avoid any sudden flaring when you finish the welding process and the welding arc is broken. When the welding arc is broken it is possible for residual arc to flare from the molten welding pool which can be hazardous if the helmet has already automatically adjusted the DIN shade to a lighter setting. To accommodate for this, the helmet is equipped with a **Delay Time Switch** for additional eye protection which can be set to three positions - depending on the welding process:

- 1) **Long** = 0.6 to 0.9 second delay
- 2) **Middle** = 0.4 to 0.6 second delay
- 3) **Short** = 0.3 to 0.5 second delay



It is important that you use the correct delay & sensitivity setting to suit your welding process and that you test the battery and filter before use.

3.4 Testing

1. Testing the Battery:

You can test the lithium battery is charged by checking that the **Battery Indicator Light** is on. The **Battery Indicator Light** is located beside the **Test** button on the control panel (see **Fig 2**). If the red light is not displaying or if the light is weak you need to replace the batteries. The helmet takes two CR2450 type batteries.

2. Testing the Filter:

You can test the filter by pressing the **Test** button on the control panel (see **Fig 2**).

If the battery indicator is on and the filter shade is not darkening when you press the **Test** button there is a fault with the filter and it should not be used to prevent the risk of injury.

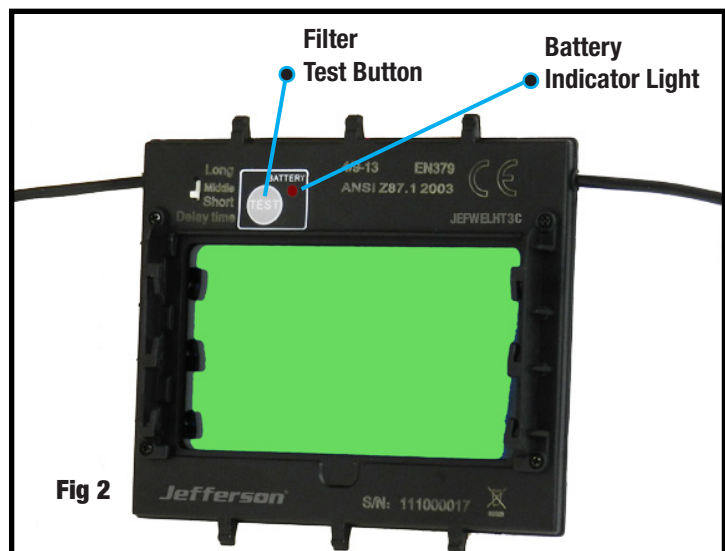

3. Operation & Safety (continued...)

3.5 The Magnifying Lens

A magnifying lens is available for this model (sold separately).
The lens is fixed over the visor shown in **Fig 3**.

3.6 Adjusting the Headgear

- It is important that the Helmet fits the user comfortably and securely before welding begins.
- The helmet can be adjusted in 4 places to allow you to establish the best fit (see Fig 4).

1. Top Headband - Adjust the depth of the headband to fit accordingly

2. Filter Harness - Adjust to set the correct distance between the welders eyes and the filter lens

3. Back Headband - Loosen or tighten to attain a comfortable and secure fit

4. Incline Angle - Adjust to set the incline angle of the helmet relative to the welders face and the position of the welders eyes relative to the filter lens

Note: This helmet headband is designed with a mechanism that helps to adjust the centre of gravity on the helmet when the visor is up and down. This mechanism helps to reduce the weight on the neck and reduce fatigue - making the helmet more comfortable and secure when you are working.

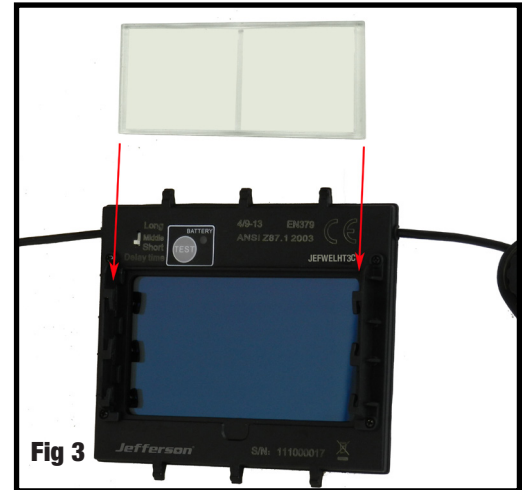

Fig 3

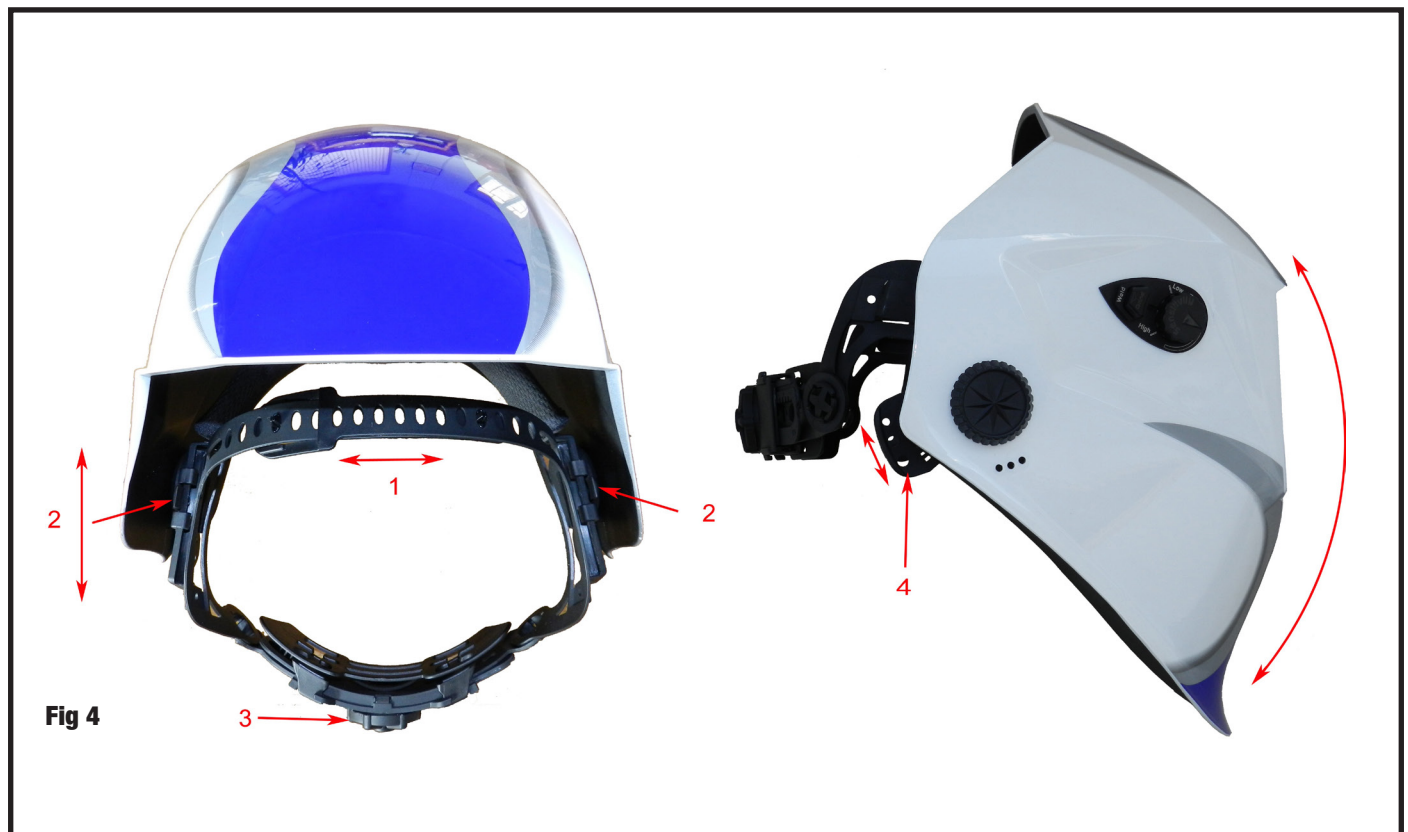
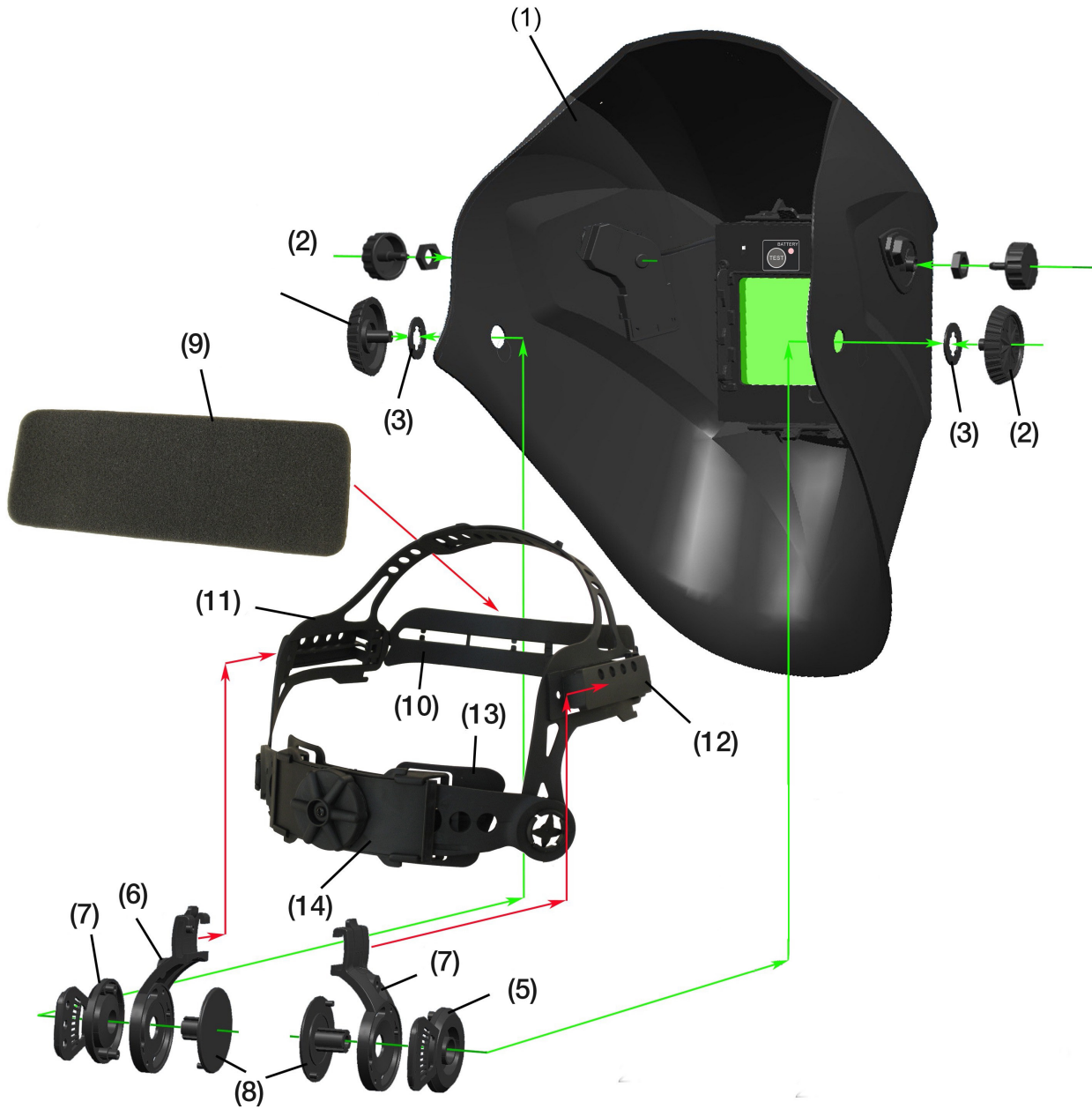

Fig 4

4. Replacement Parts List (part 1)



1. Shell (Welding Mask)	8. Headband fixing screw rack
2. 2x Block Nut	9. Sweatband (cloth)
3. 2x check washer	10. Front band
4. Angle adjusting shim (left)	11. Left band
5. Angle adjusting shim (right)	12. Right band
6. Headband rack (left)	13. Black Elastic Pad
7. Headband rack (right)	14. Headband regulator assembly

5. Replacement Parts List (Part 2)

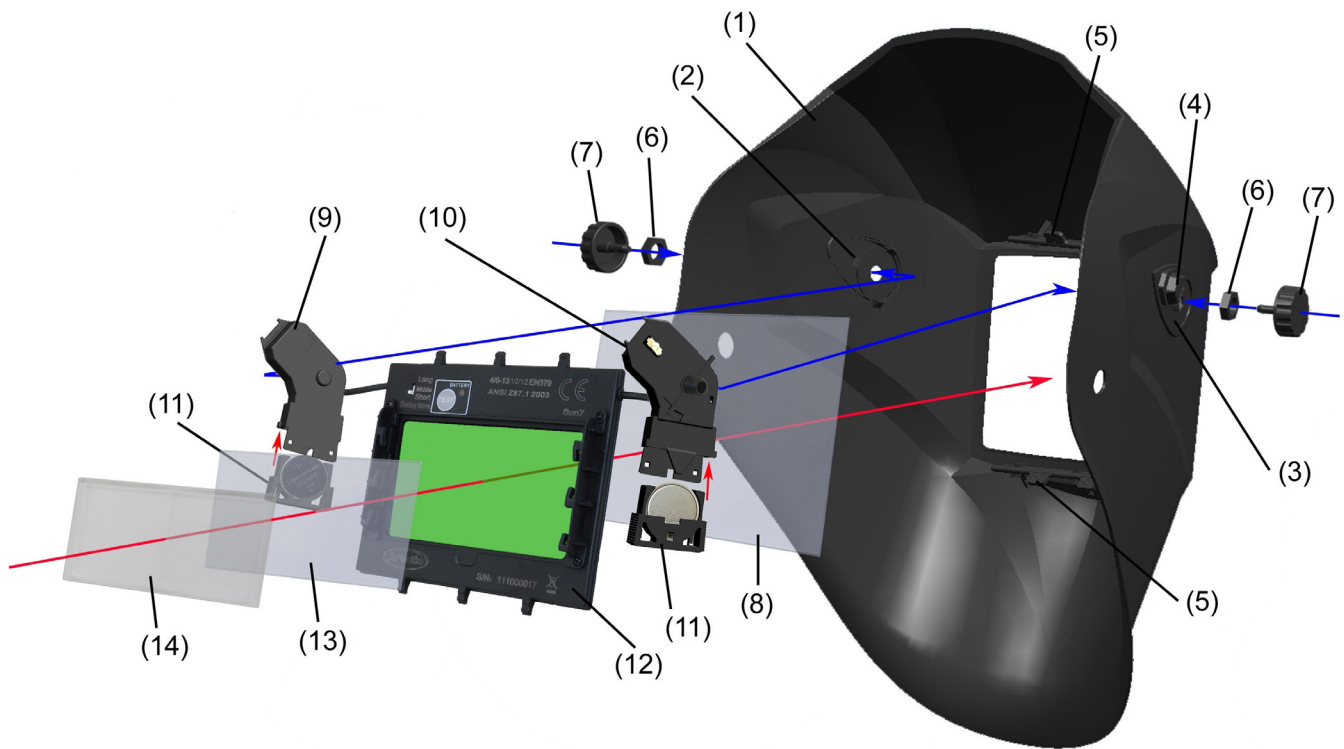

1. Shell (Welding Mask)	8. Front Cover Lens
2. Shade Scale Plate	9. Shade Screen
3. Sensitivity Scale Plate	10. Sensitivity Screen
4. Welding / Grinding Mode Switch	11. Lithium Battery Housing
5. Filter setting Frame	12. Auto-Darkening Filter
6. 2x Shade Nuts	13. Inside Cover Lens
7. 2x Shade Sensitivity Knobs	14. Magnifying Lens (sold separately)

EC Declaration Of Conformity

We, Jefferson Professional Tools & Equipment, as the authorised European Community representative of the manufacturer, declare that the following equipment conforms to the requirements of the following Directives:

EU 2016/425 - Personal protective equipment (PPE)
EN 379: 2003 + A1 : 2009 - Personal eye-protection - Automatic Welding Filters
EN 166:2001 - Personal eye protection. Specifications
EN 175:1997 - Personal protection - Equipment for eye and face protection during welding and allied processes
2011/65/EU - RoHS - Restriction of Hazardous Substances Directive

Equipment Category:

Personal Protective Equipment:

Automatic Welding Filter, Variable Shade, Grinding Mode:

- *Optical Class: 1*
- *Diffusion of Light Class: 1*
- *Variations in Luminous Transmittance Class: 1*
- *Angle Dependence of Luminous Transmittance: 2*

Face Shield:

- *Polyamide, Safety plates, Active welding filter, Protection against high-speed particles, medium energy impact [B]*

Product Name/Model:

JEFWELHT5TP

Notified Body:

ECS European Certification Service (1883) Germany

A copy of this certificate has been submitted to the European Commission and to the EU Member State, United Kingdom

Signed by:

Stephen McIntyre
Operations Director
11 December 2019



Position in the company:

Date:

Name and address of manufacturer or authorised representative:

Jefferson Tools, Herons Way, Chester Business Park, Chester, United Kingdom, CH4 9QR
Telephone: +44 (0)1244 646 048 Fax: +44 (0)1244 241 191 Email: enquiries@jeffersonstools.com

LIMITED WARRANTY STATEMENT

Jefferson Professional Tools & Equipment, or hereafter "Jefferson" warrants its customers that its products will be free of defects in workmanship or material. Jefferson shall, upon suitable notification, correct any defects, by repair or replacement, of any parts or components of this product that are determined by Jefferson to be faulty or defective.

This warranty is void if the equipment has been subjected to improper installation, storage, alteration, abnormal operations, improper care, service or repair.

Warranty Period

Jefferson will assume both the parts and labour expense of correcting defects during the stated warranty periods below.

All warranty periods start from the date of purchase from an authorised Jefferson dealer. If proof of purchase is unavailable from the end user, then the date of purchase will be deemed to be 3 months after the initial sale to the distributor.

1 Year

- Auto Darkening Welding Helmet - JEFWELHT5TP

90 Days

- All replacement parts purchased **outside** of the warranty period

Important: All parts used in the repair or replacement of warranty covered equipment will be subject to a minimum of 90 days cover or the remaining duration of the warranty period from the original date of purchase.

Warranty Registration / Activation

You can register and activate your warranty by visiting the Jefferson Tools website using the following address:

www.jeffersontools.com/warranty and completing the online form. Online warranty registration is recommended as it eliminates the need to provide proof of purchase should a warranty claim be necessary.

Warranty Repair

Should Jefferson confirm the existence of any defect covered by this warranty the defect will be corrected by repair or replacement at an authorized Jefferson dealer or repair centre.

Packaging & Freight Costs

The customer is responsible for the packaging of the equipment and making it ready for collection. Jefferson will arrange collection and transportation of any equipment returned under warranty. Upon inspection of the equipment, if no defect can be found or the equipment is not covered under the terms of the Jefferson warranty, the customer will be liable for any labour and return transportation costs incurred.

These costs will be agreed with the customer before the machine is returned.

** Jefferson reserve the right to void any warranty for damages identified as being caused through misuse*

Warranty Limitations

Jefferson will not accept responsibility or liability for repairs made by unauthorised technicians or engineers. Jefferson's liability under this warranty will not exceed the cost of correcting the defect of the Jefferson products.

Jefferson will not be liable for incidental or consequential damages (such as loss of business or hire of substitute equipment etc.) caused by the defect or the time involved to correct the defect. This written warranty is the only express warranty provided by Jefferson with respect to its products.

Any warranties of merchantability are limited to the duration of this limited warranty for the equipment involved.

Jefferson is not responsible for cable wear due to flexing and abrasion. The end user is responsible for routine inspection of cables for possible wear and to correct any issues prior to cable failure.

Claiming Warranty Coverage

The end user must contact Jefferson Professional Tools & Equipment (Tel: +44 (0) 1244 646 048) or their nearest authorised Jefferson dealer where final determination of the warranty coverage can be ascertained.

Step 1 - Reporting the Defect

Online Method:

- Visit our website www.jeffersonstools.com/warranty and complete the Warranty Returns form. You can complete the form online and submit it to us directly or download the form to print out and return by post.

Telephone Method:

Contact your Jefferson dealer or sales representative with the following information:

- Model number
- Serial number (usually located on the specification plate)
- Date of purchase

A Warranty Returns form will be sent to you for completion and return by post or fax, together with details of your nearest authorised Jefferson repair centre. On receipt of this form Jefferson will arrange to collect the equipment from you at the earliest convenience.

Step 2 - Returning the Equipment

It is the customer's responsibility to ensure that the equipment is appropriately and securely packaged for collection, **together with a copy of the original proof of purchase**. Please note that Jefferson cannot assume any responsibility for any damage incurred to equipment during transit. Any claims against a third party courier will be dealt with under the terms & conditions of their road haulage association directives.

Please note: Jefferson will be unable to collect or process any warranty requests without a copy of the original proof of purchase.

Step 3 - Assessment and Repair

On receipt, the equipment will be assessed by an authorised Jefferson engineer and it will be determined if the equipment is defective and in need of repair and any repairs needed are covered by the warranty policy. In order to qualify for warranty cover all equipment presented must have been used, serviced and maintained as instructed in the user manual.

Where repair is not covered by the warranty a quotation for repair, labour costs and return delivery will be sent to the customer (normally within 7 working days).

Note: If the repair quotation is not accepted Jefferson Professional Tools & Equipment will invoice **1 hour labour time at £30 per hour plus return carriage costs (plus VAT)**.

In cases where no fault can be found with the equipment, or, if incorrect operation of the equipment is identified as the cause of the problem, a minimum of 1 hour labour at **£30 per hour plus carriage costs** will be required before the equipment will be despatched back to the customer.

Any equipment repaired or replaced under warranty will normally be ready for shipment back to the customer within 7 working days upon receipt of the equipment at an authorised Jefferson Repair centre (subject to part availability). Where parts are not immediately available Jefferson will contact you with a revised date for completion of the repair.

General Warranty Enquiries

For any further information relating to Jefferson warranty cover please call **+44 (0) 1244 646 048** or send your enquiry via email to warranty@jeffersonstools.com

Disclaimer:

The information in this document is to the best of our knowledge true and accurate, but all recommendations or suggestions are made without guarantee. Since the conditions of use are beyond their control, Jefferson Tools® disclaim any liability for loss or damage suffered from the use of this data or suggestions. Furthermore, no liability is accepted if use of any product in accordance with this data or suggestions infringes any patent. Jefferson Tools® reserve the right to change product specifications and warranty statements without further notification. All images are for illustration purposes only.

ENVIRONMENTAL PROTECTION



**PLEASE
RECYCLE**

Recycle any packaging and unwanted materials instead of disposing of them as waste. All tools, accessories and packaging should be sorted, taken to a recycling centre and disposed of in a manner which is compatible with the environment.

When the product becomes completely unserviceable, reaches the end of its working life and requires disposal, drain off any fluids (if applicable) into approved containers and dispose of the product and the fluids according to local regulations.

WEEE Waste Electrical and Electronic Equipment Statement



Information on Disposal for Users of Waste Electrical & Electronic Equipment

This symbol on the product(s) and / or accompanying documents means that used electrical and electronic products should not be mixed with general household waste. For proper treatment, recovery and recycling, please take this product(s) to designated collection points where it will be accepted free of charge.

For private households:

Dispose of this product at the end of its working life and in compliance with the EU Directive on Waste Electrical and Electronic Equipment (WEEE). Contact your local solid waste authority for recycling information for this equipment.

Disposing of this product correctly will help save valuable resources and prevent any potential negative effects on human health and the environment, which could otherwise arise from inappropriate waste handling.

Please contact your local authority for further details of your nearest designated collection point.

Penalties may be applicable for incorrect disposal of this waste, in accordance with your national legislation.

For business users in the European Union:

If you wish to discard electrical and electronic equipment, please contact your dealer or supplier for further information.

Information on Disposal in other Countries outside the European Union:

This symbol is only valid in the European Union. If you wish to discard this product please contact your local authorities or dealer and ask for the correct method of disposal.

RoHS (2014/35/EU - Restriction of Hazardous Substances)



Based on randomly-sampled examination of the evaluated product, the results of Lead, Cadmium, Hexavalent chromium, Polybrominated biphenyls (PBB), Polybrominated diphenyl ethers (PBDE) in tested samples comply with the limits as set by RoHS Directive 2011/65/EU ANNEX II; recasting 2002/95/EC.

IMPORTANT! SAFETY FIRST!

Before attempting to use this product please read all the safety precautions and operating instructions outlined in this manual to reduce the risk of fire, electric shock or personal injury.

Jefferson Tools,
Herons Way,
Chester Business Park,
Chester, United Kingdom, CH4 9QR
Tel. +44 (0)1244 646 048
Email: sales@jeffersonstools.com

www.jeffersonstools.com