

JEFFERSON GEARBOX WASHER

JEFWASPGR090HP-DL JEFWASPGR130HP-PT

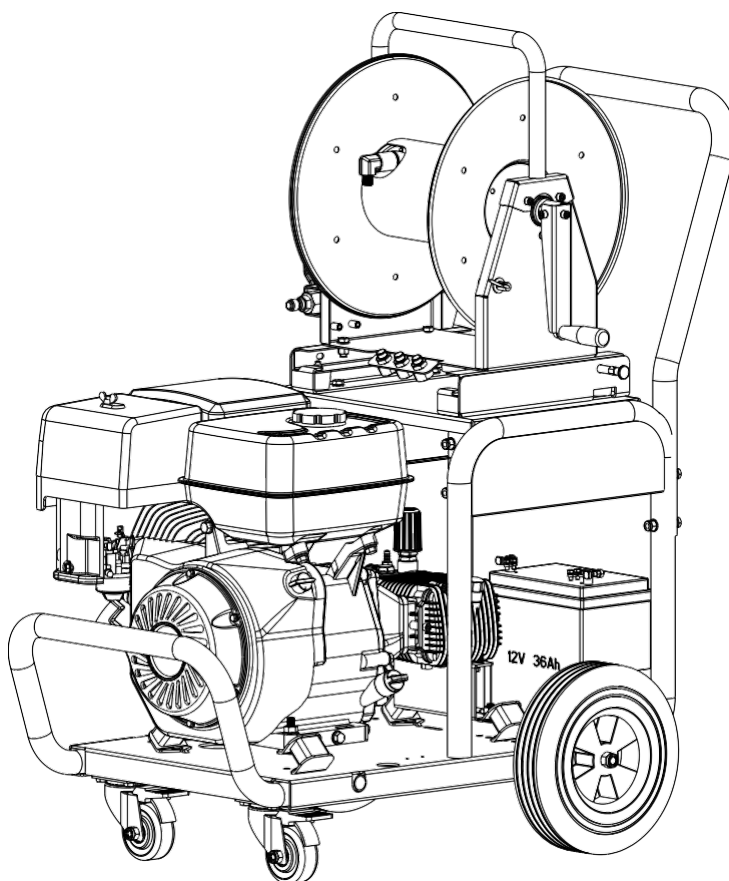

IMPORTANT SAFETY INSTRUCTIONS

Before using this product, please read this user manual, if you do not understand any of the instructions within, please do not use the product and consult your retailers or the manufacturer. Failure to follow these instructions may result in damage to the product, property and/or cause personal injury to the user or bystanders.

Please read and comply with these original instructions prior to the initial operation of your appliance and store them for later use or subsequent owners. Apart from the notes contained herein the general safety provisions and rules for the prevention of accidents of the legislator must be observed.

IMPORTANT SAFETY INSTRUCTIONS AND GUIDELINES

WARNING- Read and follow all instructions.

Failure to follow all instructions in this manual may result in severe personal injury or death. Keep this manual and refer to it for Safety Instructions, Operating Procedures, and Warranty.

This manual contains information that is important for you to know and understand. This information relates to protecting YOUR SAFETY and PREVENTING EQUIPMENT PROBLEMS. To help you recognize this information, we use the symbols below. Please read the manual and pay attention to these sections

DANGER - indicates an imminently hazardous situation which, if not avoided, will result in death or serious injury.

CAUTION - indicates a potentially hazardous situation which if not avoided, may result in minor or moderate injury.

WARNING - indicates a potentially hazardous situation which, if not avoided, could result in death or serious injury.

! CAUTION - used without the safety alert symbol indicates a potentially hazardous situation which, if not avoided, may result in property damage.

Improper maintenance and operation are responsible for the majority of accidents involving Petrol pressure washers. The largest portion of these could be prevented by recognizing the basic safety rules and precautions. Most accidents can be avoided if the operator recognizes a potentially hazardous situation before it happens and by observing appropriate safety rules and procedures as outlined in this manual. Basic safety precautions are outlined in the SAFETY portion of this manual and throughout the text in this manual where a potential hazard might occur. Hazards that MUST be avoided to prevent serious injury follow headers marked

DANGER Or WARNING. These same precautions are placed as labels on the tool itself. NEVER use this pressure washer for applications that are NOT specified in this manual.

DANGER - risk to breathing in harmful gases.

- Running engine gives off carbon monoxide, an odourless, colourless, poison gas.
- Breathing carbon monoxide can cause nausea, fainting or death.
- Some chemicals or detergents may be harmful if inhaled or ingested, causing severe nausea, fainting or poisoning.



ALWAYS Operate pressure washer in a well ventilated area. Avoid enclosed areas such as garages, basements, etc.
ALWAYS Keep exhaust gas from entering a confined area through windows, doors, ventilation intakes, or other openings.
ALWAYS follow manufacturers recommendations, use a respirator or mask whenever there is a chance that vapours may be inhaled.

ALWAYS use the only fluids specifically recommended for high pressure washers.

NEVER operate unit in a location occupied by humans or animals.

NEVER use chlorine bleach or any other corrosive compound.



DANGER - Risk of explosion or fire

- Fuel and its vapours are extremely flammable and explosive.
- Fire or explosion can cause severe burns or death.

ALWAYS shut off engine and allow it to cool a least 2 minutes before adding fuel to the tank.

ALWAYS use care in filling tank to avoid spilling fuel. Move pressure washer away from fuelling area before starting engine.

ALWAYS Keep maximum fuel level below top of tank to allow for expansion.

ALWAYS operate and fuel equipment in well ventilated areas free from obstructions. Equip areas with fire extinguishers suitable for gasoline fires.

ALWAYS keep pressure washer a minimum of four feet away from surfaces (such as houses, automobiles, or live plants) that could be damaged from muffler exhaust heat.

ALWAYS Store fuel in an approved container, in a secure location away from work area.

NEVER spray flammable liquids

NEVER operate pressure washer in an area containing dry brush or weeds.

IMPORTANT SAFETY INSTRUCTIONS AND GUIDELINES CONT.**WARNING - Risk of fall hazard**

- Use of pressure washer can create puddles and slippery surfaces.
- Kickback from spray gun can cause you to fall.



Keep the area of operation clear of all persons, particularly small children, pets and obstacles.

Do not operate the product when fatigued or under the influence of alcohol or drugs. Stay alert at all times.

If engine does not start after two pulls, squeeze trigger of gun to relieve pump pressure. Pull starter cord slowly until resistance is felt. Then pull cord rapidly to avoid kickback and prevent hand or arm injury.

Do not overreach or stand on an unstable support.

The cleaning area should have adequate slopes and drainage to reduce the possibility of a fall due to slippery surfaces.

Be extremely careful if you must use the pressure washer from a ladder, scaffolding, or any other similar location.

Beware of kick-back force and the sudden torque on the spray gun assembly when operating the trigger. Firmly grasp spray gun with both hands to avoid injury when spray gun kicks back.

WARNING - Risk to fluid injection

- The high pressure stream of water that this equipment produces can cut through skin and its underlying tissues, leading to serious injury and possible amputation. Spray gun traps high water pressure, even when engine is stopped and water is disconnected, which can cause injury.



ALWAYS point spray gun in safe direction and squeeze trigger, to release high pressure, every time you stop engine.

NEVER place hands in front of nozzle.

MAKE SURE hose and fittings are tightened and in good condition. Never hold onto the hose or fittings during operation.

DO NOT allow hose to contact muffler.

NEVER attach or remove wand or hose fittings while system is pressurized.

NEVER use a spray gun which does not have a trigger lock or trigger guard in place and in working order.

ONLY USE hose and high pressure accessories rated for pressure higher than your pressure washer's p.s.i.

To relieve system pressure, shut off engine, turn-off water supply, and pull gun trigger until water stops flowing.

DO NOT allow CHILDREN to operate pressure washer.

NEVER repair leaking connections with sealant of any kind. Replace o-ring or seal.

NEVER connect high pressure hose to nozzle extension.

DO NOT secure spray gun in open position.

DO NOT leave spray gun unattended while machine is running.

ALWAYS be certain spray gun, nozzles and accessories are correctly attached.

NEVER aim spray gun at people, animals, or any electrical device and the machine itself.

DANGER - Risk of chemical burn

- Use of acids, toxic or corrosive chemicals, poisons, insecticides, or any kind of flammable solvent with this product could result in serious injury or death.



DO NOT use acids, gasoline, kerosene, or any other flammable detergents, cleaners and degreasers recommended for use in.

Wear protective clothing to protect eyes and skin from contact

DO NOT use chlorine bleach or any other corrosive compound materials in this product.

Use only household pressure washers with sprayed materials.

WARNING - Risk of electrical shock

- Risk of electrocution.
- Contact with power source can cause electric shock or burn.



Unplug any electrically operated product before attempting to clean it.

Direct spray away from electric outlets and switches.

NEVER spray near power source.

DO NOT touch the plug with wet hands.

When servicing the pressure washer: Disconnect the spark plug wire and place it where it cannot contact the plug.

DO NOT check for spark with the plug removed. Use only approved spark plug testers.

IMPORTANT SAFETY INSTRUCTIONS AND GUIDELINES

DANGER - Risk of hot surfaces

- Contact with hot surfaces, such as engines exhaust components, could result in serious burn.

During operation, touch only the control surfaces of the pressure washer.
Keep children away from the pressure washer at all times. They may not be able to recognize the hazards of this product.
DO NOT let hoses come in contact with very hot engine muffler during or immediately after use of your pressure washer. AVOID hot exhaust gases



DANGER - Risk of moving parts.

- Starter and other rotating parts can entangle hands, hair, clothing, or accessories.

NEVER operate pressure washer without protective housing or covers.
DO NOT wear loose clothing, jewellery or anything that may be caught in the starter or other rotating parts.
Tie up long hair and remove jewellery



DANGER - Risk of eye injury

- Spray can splash back or propel objects.

ALWAYS wear safety goggles when using this equipment or in vicinity of where equipment is in use.
Before starting the pressure washer, be sure you are wearing adequate safety goggles.
NEVER substitute safety glasses for safety goggles.



CAUTION - Improper treatment of pressure washer can damage it and shorten its life and void your warranty

NEVER pull water supply hose to move pressure washer. This could damage hose and / or pump inlet.
DO NOT use hot water, use cold water only.
NEVER turn water supply off while pressure washer engine is running or damage to pump will result.
DO NOT stop spraying water for more than two minutes at a time. Pump operates in bypass mode when spray gun trigger is not pressed. If pump is left in bypass mode for more than two minutes internal components of the pump can be damaged.
Before starting pressure washer in cold weather, check all parts of the equipment to be sure ice has not formed there.
DO NOT use the pressure washer if excessive noise or vibration is present. Have it repaired immediately.

Please wear proper PPE when operating the washer.



Proper Apparel



Electrically
Non-conductive Gloves



Ear Protection



Non-skid Footwear

Parts Identification and Features

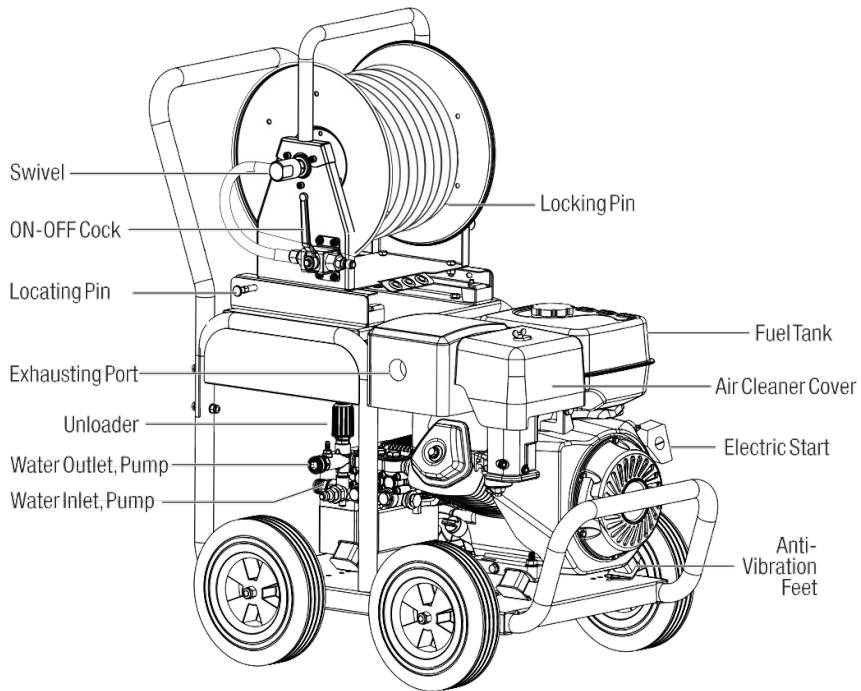
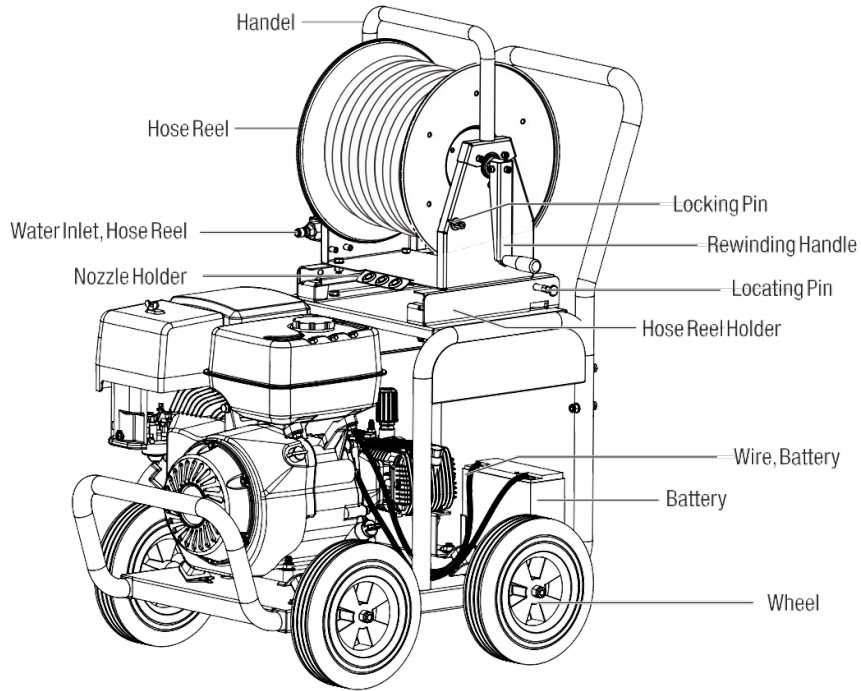

Parts Identification and Features

Triplex Pump

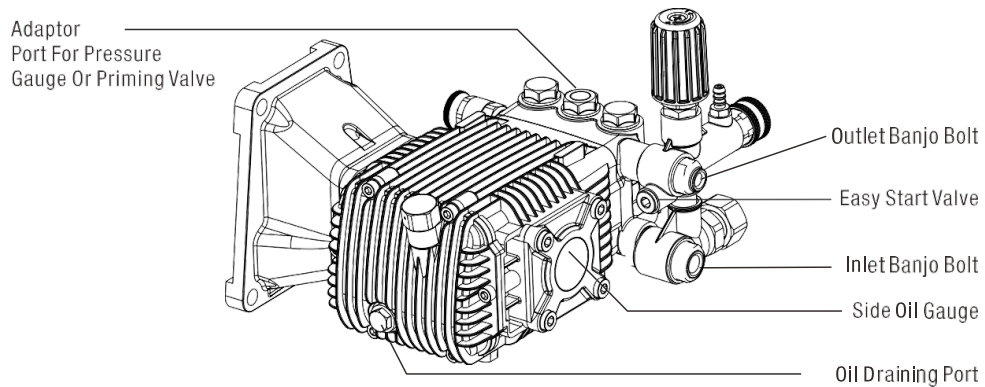
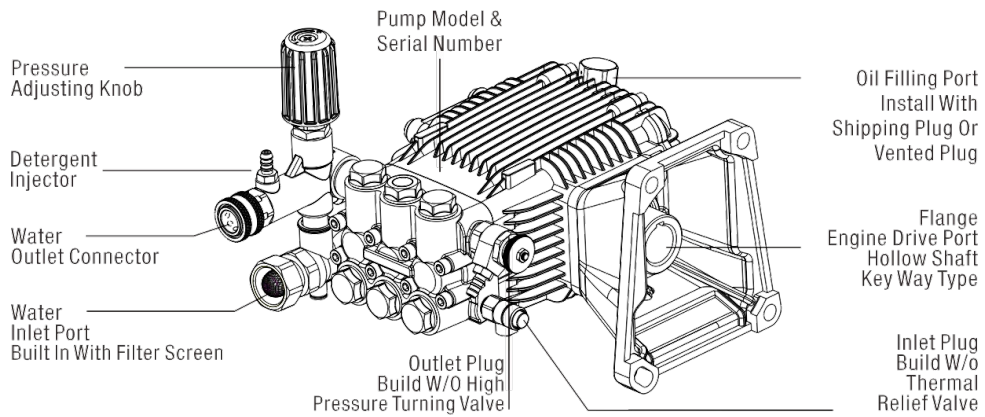

Gear-reduction Box

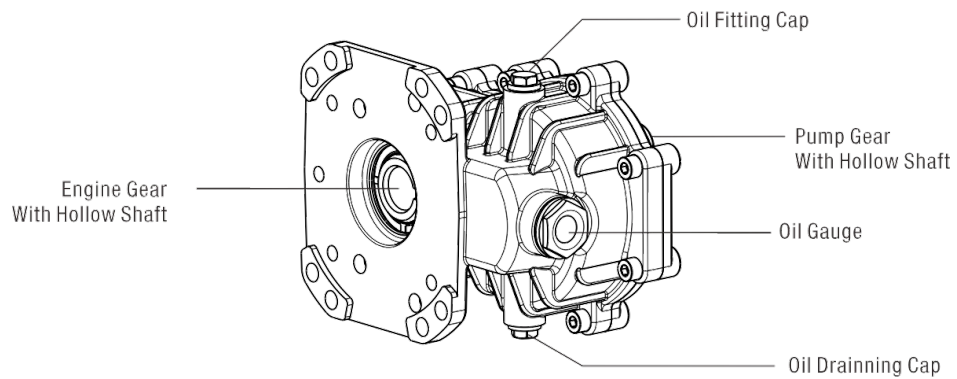

Parts Identification and Features

Petrol Engine

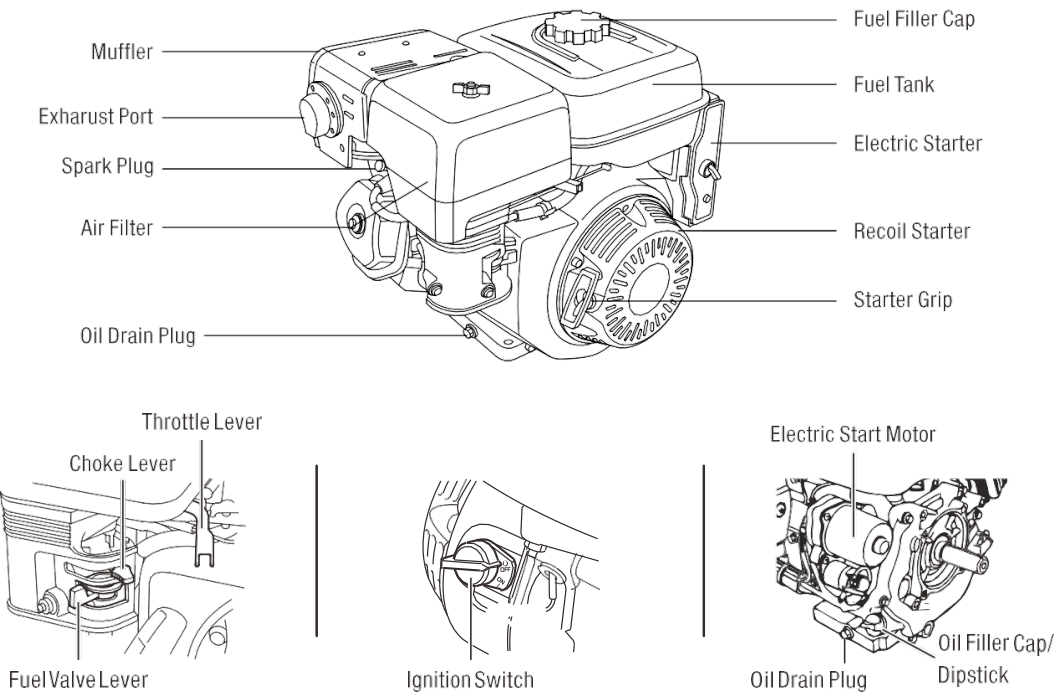

Diesel Engine

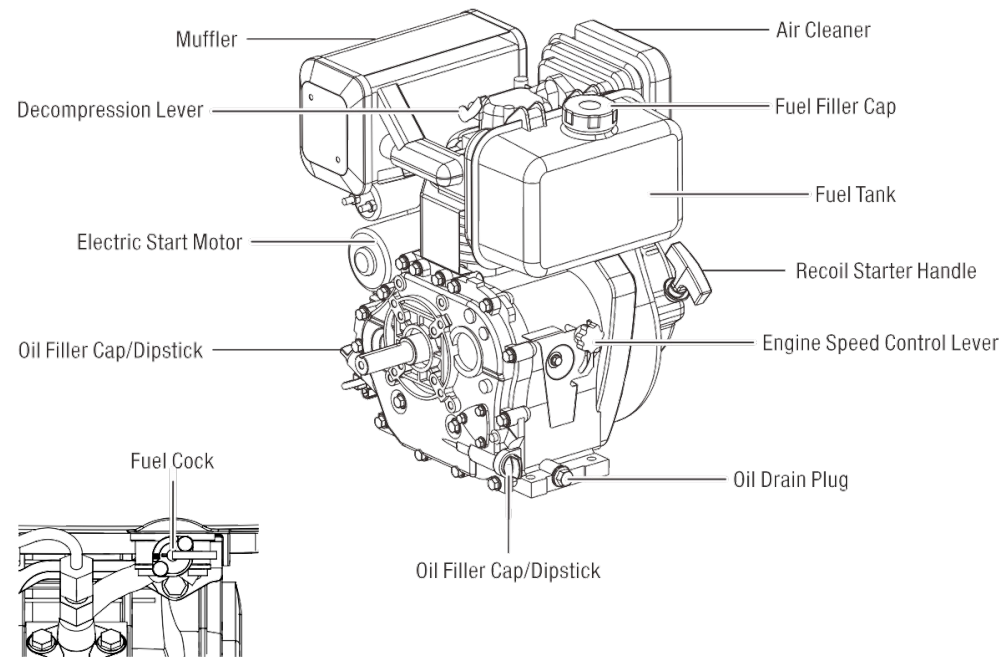

Parts Identification and Features

General Technology

PSI: Pounds per square inch - common unit measure used for water pressure, air pressure, hydraulic pressure and pounds of force

GPM: Gallons per minute (litres per minute [metric]) - common unit measure used for flow rate of water.

Bypass Mode: In bypass mode, high pressure pump recirculates water because spray gun trigger is not pulled.

High Pressure Washer Pump

1. Pump Model & Serial Number: It contains the year, month and day of production, and can track the batch of materials assembler and tester. Please provide the serial no. along with the pump model and version when ordering spare parts and reporting any issues of concern.
2. Pressure Adjusting Knob: To raising or reduce the pressure by turn the knob.
3. Detergent Injector: Use to siphon detergent or other pressure washer chemicals into the low pressure stream.
4. Water Outlet Connector: To connect high pressure hose.
5. Water Inlet With Filter Screen: Connect garden hose here, and always have the filter screen present in it.
6. Red Shipping Plug Attached With Vent Plug: the pump is ship with red shipping plug to prevent oil leaking during transportation. Replace with the attached vent plug before using.
7. Thermal Relief Valve: Cycles water through pump when water reaches 125-155°F (50-68 °C). Warm water will discharge from pump onto ground. This valve can prevent internal pump damage
8. High Pressure Turning Valve: This is a valve can discharges the air in the pump and water in-taking pipe line, enhance pump sucking ability, and allow to suck from the barrel and 1M deep

Petrol Engine

1. Air Cleaner/Filter: Protects engine by filtering dust and debris out of intake air
2. Fuel Tank: Fill tank with regular unleaded fuel. Always leave room for fuel expansion.
3. Throttle Lever: Sets engine in starting mode for recoil starter
4. Choke Lever: Prepares a cold engine for starting.
5. Fuel Valve Lever: Used to turn fuel on and off to engine
6. Recoil Starter: Use for starting the engine manually.
7. Ignition Switch: Set this switch to "On" before using recoil starter. Set switch to "Off" to switch off engine.
8. Oil Fill Cap: Fill engine with oil here.

Diesel Engine

1. Air Cleaner: The air cleaner prevents airborne contaminants from entering the diesel engine
2. Fuel Tank: The fuel tank is a reservoir that holds diesel fuel.
3. Starter Motor: It is powered by the battery and engage the flywheel in motion to start the diesel engine
4. Fuel Cock: To turn "ON" or "OFF" the fuel supply to the injection pump
5. Recoil Starter: Use for starting the engine manually.
6. Decompression Lever: It helps to start the engine by reducing the effort needed to pull the recoil starter handle.

Unpacking and Assembly

Unpacking

1. CAUTION - Unit is heavy. Do not attempt to lift and remove the pressure washer unit from the carton without carefully cut the box down the sides then remove the tool and any accessories from the box. Make sure that all items are included.
2. Remove and discard the clear cap securing the operator's manual bag to the pump breather tube.
3. Inspect the tool carefully to make sure no breakage or damage occurred during shipping.
4. Do not discard the packing material until you have carefully inspected satisfactorily operated the tool.
5. If any parts are damaged or missing, please contact with the dealer.

Assembly the Handle

Place the handle onto the frame, insert the bolt through the tube, put the nut on and tighten.

Assembly the Mounting Base

Put the two base onto the plate as shown, insert the bolt, put the nut on and tighten.

Unpacking and Assembly

7. Assembly the Mounting Base Put the two base onto the plate as shown, insert the bolt, put the nut on and tighten.
8. Put the Hose Reel Onto the Frame. Pull the Locking Pin out, put the hose reel inside the base and place under the hooker, alignment the locking hole and put back the locking pin to lock the hose reel in place.

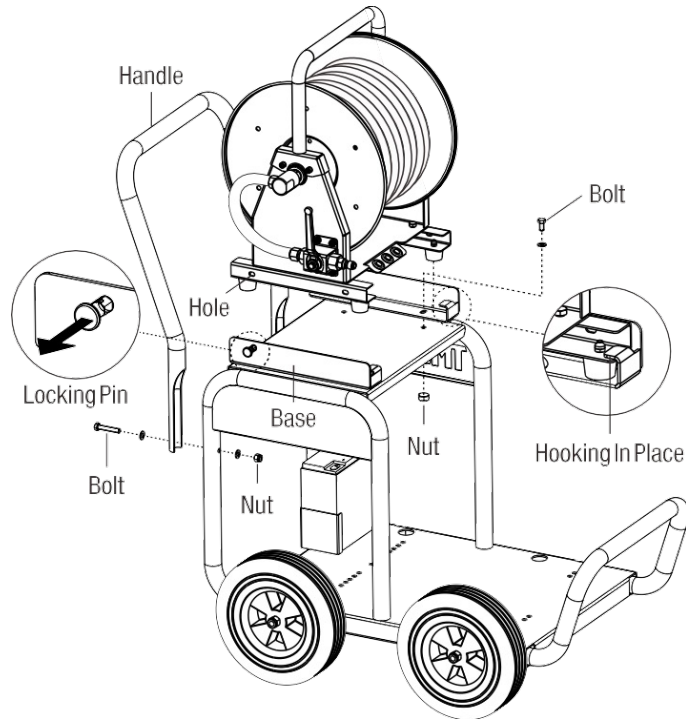

Adding Oil to Triplex Pump

WARNING - Operating the pump with low oil or no oil can cause permanent damage and VOIDS THE WARRANTY. Check the pump oil level to make sure it is correct.

1. Using an 17mm open-end wrench or socket wrench, remove shipping plug from pressure pump. Discard shipping plug.
2. Remove pump breather plug from parts bag and insert it into pressure pump.
3. Tighten pump breather plug securely by hand. Do not use open-end wrench or socket wrench to tighten.
4. Check the sight glass to ensure pump oil is at 1/2 of the sight glass level. 5. Add oil to pressure pump if level is below indicator on oil gauge.
6. Oil type API SF SAE 10W-30 or 15W/40.
7. Change after the first 30 hours, then subsequently 100 hours.
8. We recommend the use high-quality NON-DETERGENT oils, if classified for service SF, SG, SH, SJ or higher. DO NOT use special additives.

Outdoor temperatures determine the proper oil viscosity.

**Below 40°F (4°C) the use of SAE 30 will result in hard starting.

**Above 80°F (27°C) the use of 10W30 may cause increased oil consumption.

Check oil level more frequently.

Setting Up Before Use (Petrol Engine)

Add Oil To The Petrol Engine

1. Place pressure washer on a flat, level surface.
2. Clean area around oil fill and remove yellow oil fill cap.
3. Using oil funnel (optional), slowly pour contents of provided oil bottle into oil fill opening.
4. Replace oil fill cap and fully tighten.

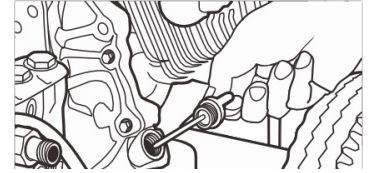

NOTICE! Improper treatment of pressure washer can damage it and shorten its life. DO NOT attempt to crank or start the engine before it has been properly serviced with the recommended oil. This may result in an engine failure.

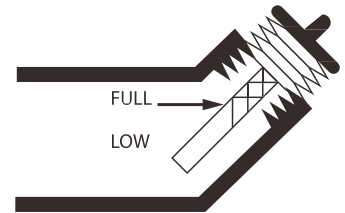

Add Fuel To the Petrol Engine

Failure to use fuel as recommended in this manual will void the warranty.

DO NOT use unapproved Petrol such as E85 (85% ethanol/15% gasoline).

DO NOT mix oil with petrol.

DO NOT modify engine to run on alternate fuels.

Mix in a fuel stabilizer when adding fuel to pressure washer to protect fuel system from forming gum deposits. If engine doesn't turn properly after fuelling, switch fuel brands. The engine is certified to run on petrol. The emission control system for this engine is EM (Engine Modifications).

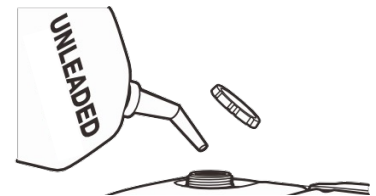
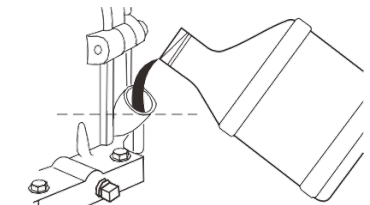

WARNING! Fuel and fuel vapour are extremely flammable and explosive. Fire or explosion from misuse of fuel can cause severe burns and even death.

When adding fuel to pressure washer, observe the following steps:

1. Turn pressure washer OFF and let it cool for at least two minutes before removing fuel cap. Loosen fuel cap slowly to release pressure.
2. Fill fuel tank outdoors.
3. Do NOT overfill fuel tank. Leave room for fuel to expand.
4. Wait for spilled fuel to evaporate before cranking engine.
5. Keep fuel away from sparks, open flames, pilot lights, heat and other ignition sources.
6. Do NOT light a cigarette or smoke near open fuel tank or container.
7. Clean area around fuel fill cap and slowly remove cap to allow any pressure to escape.
8. Slowly add unleaded gasoline (A) to fuel tank (B). Use extreme caution not to fill fuel above baffle (C). This allows appropriate space for fuel expansion.
9. Install fuel cap and allow any spilled fuel to evaporate before starting engine.

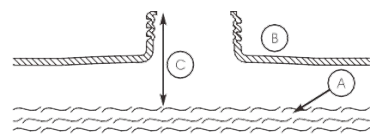
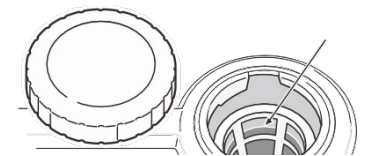

Setting Up Before Use (Diesel Engine)

Notice! Improper treatment of pressure washer can damage it and shorten its life.

DO NOT attempt to crank or start the engine before it has been properly serviced with the recommended oil. This may result in an engine failure.

Checking Engine Oil

- Place pressure washer on a flat, level surface.
- Remove oil cap/dipstick and wipe with clean cloth.
- Fully reinsert oil cap/dipstick but do not screw in.
- Remove oil cap/dipstick, the oil level should be between the upper level and L level.
- Fully reinsert oil cap/dipstick and hand tighten. Do not over tightening it.

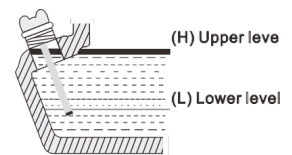
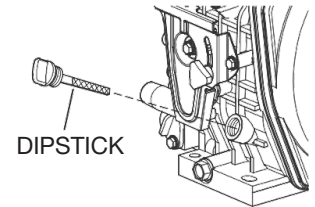

Adding Engine Oil

- Place pressure washer on a flat, level surface.
- Remove oil cap and add indicated amount of oil at either one of the filler ports, wait one minuted and check oil level, add more oil if necessary.
- Fully reinsert oil cap and hand tighten it.

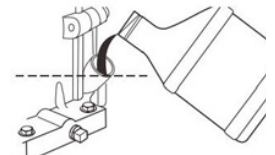

Engine Oil Recommendations

SAE 10W-30 is recommended for general use. Other viscosities shown in the chart may be used when the average temperature in your area is within the indicated range.

Above 80 F(27 C)the use of 10W30 may cause increased oil consumption. Check oil level more frequently.

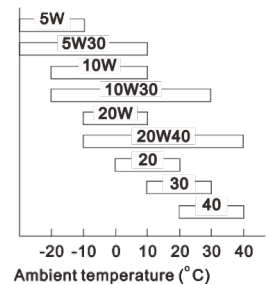

Adding Fuel

WARNING! Fuel and fuel vapour are extremely flammable and explosive. Fire or explosion from misuse of fuel can cause severe burns and even death.

When adding fuel to pressure washer,observe the following steps:

1. Turn pressure washer OFF and let it cool for at least two minutes before removing fuel cap. Loosen fuel cap slowly to release pressure.
2. Clean the area around the fuel cap
3. Remove the fuel cap from the fuel tank.
4. Fill fuel tank outdoors.
5. Stop filling when the fuel is at the same level as the middle ring on the inlet fuel screen. Never overfill the fuel tank.
6. Replace the fuel cap and hand tighten. Do not over-tightening it.

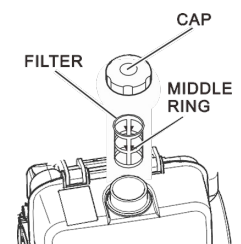

Attaching One Side Of The Connection Hose To Pump

1. Pull back the slip ring on quick-disconnect fitting of the pump outlet.
2. Insert quick-disconnect plug on the connection hose into female quick-disconnect on the pump outlet.
3. Release slip ring on female quick-disconnect and twist. Listen for "CLICK" to ensure both quick-disconnects are coupled.

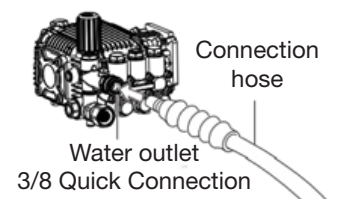

Setting Up Before Use (Diesel Engine) cont.

Attaching The Other Side Of The Connection Hose To Reel.

Similarly, attach other end of connection hose to water inlet on the hose reel. Pull down on collar of quick connect, slide onto hose reel inlet and let go of collar. Pull on hose to be sure of tight connection.

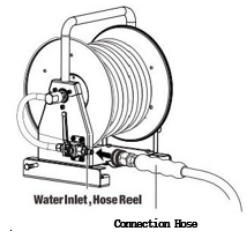

Connect Water Supply to Pump.

Before connecting garden hose to water inlet, inspect inlet screen. Clean screen if it contains debris or have it replaced if damaged. **DO NOT** run pressure jetter if inlet screen is damaged. Run water through your garden hose for 30 seconds to clean out any debris.

IMPORTANT: DO NOT use standing water for the water supply. Use **ONLY** cold water (less than 104°F/40C).

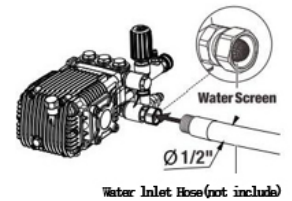

Connect the garden hose (not to exceed 50 feet in length and with the ID no Less than 1/2") to the water inlet. Tighten by hand.

Turn ON the water, hold the jetting hose and turn on the cocker of the hose reel to purge the pump system of air and impurities about 30seconds.

Connect The Nozzle Onto The Hose Fitting.

Make sure the nozzle you are using matches the pump size. Check nozzles before and after each use for clogged holes which can cause pressure to increase to dangerously high levels and damage the pump.

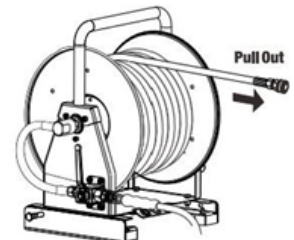

NOTICE - DO NOT attempt to crank or start the engine before it has been properly serviced with the recommended oil.

This may result in an engine failure. There **MUST** be at least ten feet (3 m) of unrestricted garden hose between the inlet and any device, such as a vacuum breaker or check valve. Damage to equipment resulting from failure to follow this instruction will **VOID WARRANTY**.

WARNING - Risk of eye injury.

Spray can splash back or propel objects.

Always wear safety goggles when using this equipment or in vicinity of where equipment is in use.



Before starting the pressure jetter, be sure you are wearing adequate safety goggles.

NEVER substitute safety glasses for safety goggles.

Attaching High Pressure Hose to Spray Gun

- Pull slip ring on female quick-disconnect fitting of high pressure hose back.
- Insert male quick-disconnect fitting on spray gun into female quick-disconnect on high pressure hose.
- Release slip ring on female quick-disconnect and twist. Listen for click to ensure both quick-disconnects are coupled.
- Pull high pressure hose and spray gun in opposite direction to ensure they do not separate.

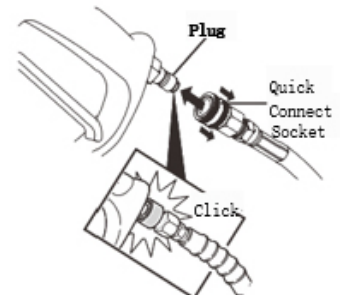

Setting Up Before Use (Diesel Engine) cont.

Connecting Spray Wand to Spray Gun
Thread spray wand onto spray gun



Connect Hose and Water Supply to Pump

Similarly, attach other end of high pressure hose to high pressure outlet on pump. Pull down on collar of quick connect, slide onto pump and let go of collar. Pull on hose to be sure of tight connection.

Before connecting garden hose to water inlet, inspect inlet screen. Clean screen if it contains debris or have it replaced if damaged. DO NOT run pressure washer if inlet screen is damaged. Run water through your garden hose for 30 seconds to clean out any debris.



IMPORTANT: DO NOT use standing water for the water supply. Use **ONLY** cold water (less than 100 F).

Connect the garden hose (not to exceed 50 feet in length and with the ID no less than 13mm) to the water inlet. Tighten by hand.

Turn **ON** the water, squeeze the trigger to purge the pump system of air and impurities

Connect Battery Cable.

Connect the Positive (+) Cable onto the Start Solenoid Terminal as shown, and connect the Negative (-) Cable to an engine mounting bolt like frame bolt, or other good engine ground connection.

NOTICE - DO NOT attempt to crank or start the engine before it has been properly serviced with the recommended oil.

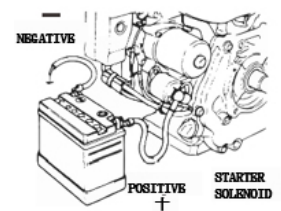

This may result in an engine failure. There **MUST** be at least ten feet (3 m) of unrestricted garden hose between the inlet and any device, such as a vacuum breaker or check valve. Damage to equipment resulting from failure to follow this instruction will **VOID WARRANTY**. Always wear safety goggles when using this equipment or in vicinity of where equipment is in use.



Before starting the pressure washer, be sure you are wearing adequate safety goggles. **NEVER** substitute safety glasses for safety goggles

Specification

	JEFWASPGR130HP-PT	JEFWASPGR090HP-DL
Max Pressure	3200psi/220bar	3200psi/220bar
Max Flow	5.54Gpm/21Lpm	5.54Gpm/21Lpm
Pump Model	DBQ-20146G4, Gearbox, Direct Drive	DBQ-20146G4, Gearbox, Direct Drive
Power And Type	13hp/390cc, OH, Eur V	9hp/456CC, Eur V
Start Type	Electric Start	Electric Start
Battery	12V, 36AH	12V, 36AH
Gun And Lance	5000psi Professional Gun, 28" Variable thread nozzle holder lance	5000psi Professional Gun, 28" Variable thread nozzle holder lance
High Pressure Hose	ID10mm x 20M, Steel Braided	ID10mm x 20M, Steel Braided
Nozzle Tips	Thread Nozzle 25°	Thread Nozzle 25°
Inlet Hose and Filter	3m Inlet Hose, Heavy Duty Brass filter	3m Inlet Hose, Heavy Duty Brass filter
Frame Type	Four wheel, pushing type	Four Wheels, Pushing Type
Wheel Size And Type	10" solid wheel X 2, Cater X 2	10" solid wheel X 2, Cater X 2
Anti-vibration System	Yes	Yes
Thermal Protection	Yes	Yes
Hose Reel	Yes	Yes
Water Suction	Yes	Yes
Nozzle Cleaner(Needle)	Yes	Yes

Safe Working Environment

Pressure Washer Location

Clearances and Air Movement

WARNING! Exhaust heat / gases can ignite combustibles, structures or damage fuel tank causing a fire. Keep at least 5 ft. (1.5m) clearance on all sides of pressure washer including overhead.



Place pressure washer in a well ventilated area, which will allow for removal of deadly exhaust gas. Do not place pressure washer where exhaust gas could accumulate and enter inside or be drawn into a potentially occupied building. Ensure exhaust gas (A) is kept away from any windows, doors, ventilation intakes, or other openings that can allow exhaust gas to collect in a confined area. Prevailing winds and air currents should be taken in to account.

WARNING! Running engine gives off carbon monoxide, an odourless, colourless, poison gas. Breathing carbon monoxide can cause headache, fatigue, dizziness, vomiting, confusion, seizures, nausea, fainting or death.



Operate pressure washer outdoors **ONLY**.

Keep exhaust gas from entering a confined area through windows, doors, ventilation intakes, or other openings. **DO NOT** start or run engine indoors or in an enclosed area, even if windows and doors are open.

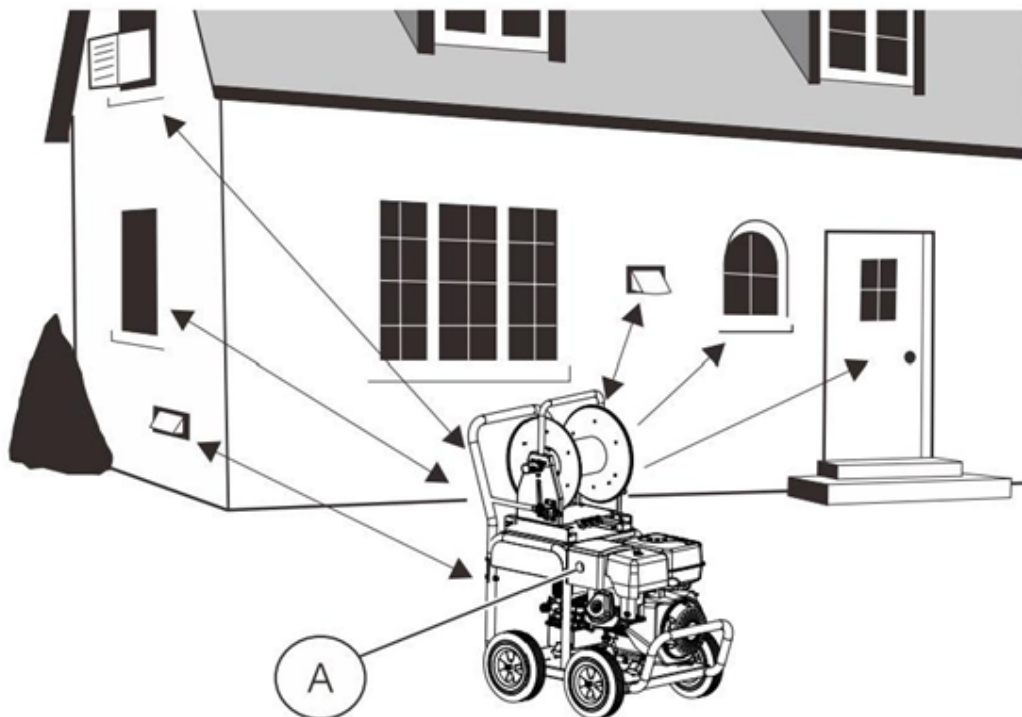

Start up and Stopping Procedure (Petrol Engine)

How to Start Your Pressure Washer

To start your pressure washer for the first time, follow these instructions step-by-step. It also applies if you have let the pressure washer sit idle for at least a day.

1. Place pressure washer near an outside water source capable of supplying water at a flow rate at least 5GPM/19LPM and no less than 20PSI/1.3BAR at pressure washer end of garden hose.
 2. Check that high pressure hose is tightly connected to spray gun and pump.
 3. Make sure unit is in a level position.
 4. Uncoil high pressure hose completely before using pressure washer.
 5. Connect garden hose to water inlet on pressure washer pump.
 6. Turn ON water, point gun in a safe direction and squeeze trigger to purge pump system of air and impurities.
 7. Attach wand to spray gun. Tighten by hand.
 8. Choose the nozzle you want to use, pull back on collar of quick connector, insert nozzle and release collar. Tug on nozzle to make sure it is securely in place.
- NOTICE! Do Not run washer without water supply connected and turned on. Failure to follow this instruction will void warranty.
9. Make sure the Battery is in good condition and well connected.
 10. Rotate fuel shut-off valve to "OPEN" position.
 11. Move throttle control lever 1/3 toward "FAST" Position.
 12. Move choke lever to "CHOKE" position.
 13. Turn the engine switch to the "ON" position, and turn the key to "START" position and hold it there until the engine starts. If the engine fails to start within 5 seconds, release the key and wait at least 10 seconds before operating the starter again.
- NOTE: For a warm engine, be sure the choke lever is in the "run" position.
14. When engine starts, slowly move choke lever to "RUN" position, as engine warms. If engine falters, move choke lever to "CHOKE" position, then to "RUN" position.
 15. After each starting attempt, where engine fails to run, always point gun in safe direction and squeeze spray gun trigger to release high pressure.

NOTE: Using the electric starter for more than 5 seconds at a time will overheat the starter motor and can damage it.

IMPORTANT: Allow the Engine to run at no load, low pressure for five minutes after each start-up so Engine can stabilize.

How to Stop Your Pressure Washer

To stop the engine method - 1. Turn the ignition switch to OFF, close the fuel valve. To stop the engine method - 2. Close the Fuel Valve and wait for the engine to stop.

NOTE: Avoid letting fuel remain in the carburetor for long periods as this can clog carburetor passages with impurities resulting in malfunctions.

Squeeze trigger to release retained high water pressure.

IMPORTANT: Spray gun traps high water pressure, even when engine is stopped and water is disconnected.

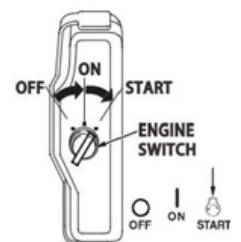
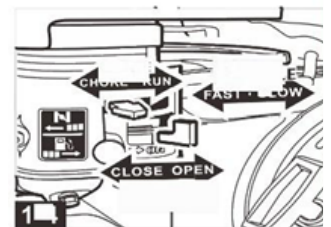
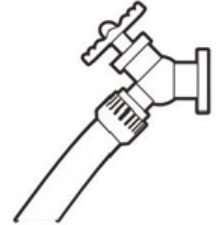

Start up and Stopping Procedure (Diesel Engine)

How to Start Your Pressure Washer

1. Place pressure washer near an outside water source capable of
2. Rotate fuel valve to "On" position
3. Turn the engine speed control knob (A) to the left (B). Slide the engine speed control knob to the START position (C). Turn the engine speed control knob to the right (D) to tighten it.
4. Make sure the Battery is in good condition and well connected.
5. Turn the Key clockwise to the START position. Release the key as soon as the engine starts. It will return to the ON position.



NOTE: If the engine fails to start:

1. Wait until the engine complete stop. Engaging the starter while the engine in rotating will damage to the start motor and flywheel.
2. Wait at least 30 seconds before you attempt to start the engine again.

IMPORTANT: Allow the Engine to run at no load, low pressure for five minutes after each start-up so Engine can stabilize.

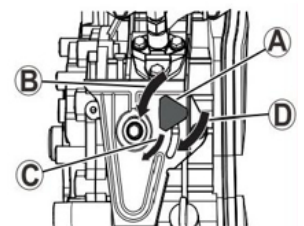

Cold Start in winter

If the engine is difficult to start in winter, see the engine manual for instructions on how to cold start.

How to Stop Your Pressure Washer

1. Release spray gun trigger and allow the engine to run unloaded for 3 minutes before shutting down.
2. Turn the engine speed control knob to the left (B), slide the knob to the STOP (A) position, turn the knob to the right (D) to tighten it.
3. Turn the engine switch to the "OFF" position and remove the key.
4. Rotate fuel valve to "OFF" position
5. Point spray gun in a safe direction, squeeze spray gun trigger to release retained high water pressure. Engage the gun trigger safety catch.



Pump Self-Priming Setup (If applicable)

NOTICE! DO NOT run the pump by self-priming it without the High Pressure Turning Valve

How the high pressure turning valve works for self priming.

This is a valve can discharges the air in the pump and water in-taking pipeline, enhance pump sucking ability, and allow to suck from the barrel and 1M deep.

1. Put the water sucking hose into the barrel, pools etc. with filter on the end.
2. Turn the VALVE CAP anticlockwise to open the valve.
3. Wait 15 to 30 seconds for pump self-priming, if the pump fail to sucking water, stop engine and check if the sucking hose or filter is block or loose in connection. And make sure do not let the pump deep sucking from more then 1Meter.
4. When the pump builds up pressure and water shooting out from bypass nipple, Close the valve and start normal using.

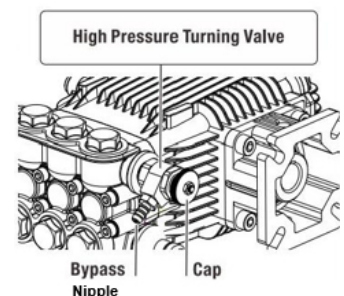

Using Nozzles

Attaching Pressure Nozzles to Spray Wand

1. Engage trigger lock on spray gun.
2. Pull slip ring on female quick-disconnect fitting of spray wand back.
3. Insert nozzle into female quick-disconnect socket on spray wand.
4. Release slip ring on female quick-disconnect and twist. Listen for "LICK" to ensure both quick-disconnects are coupled.
5. Pull the nozzle and spray wand in opposite direction to ensure they do not separate.

Nozzle Size Guide

The pressure washer comes with five spray nozzles. Each nozzle is colour coded and delivers a specific spray pattern and pressure for a particular cleaning job. The size of the nozzle determines the size of the fan spray and the pressure out of the nozzle. They are stored in receptacles on a panel mounted to the handle of the washer. Colours on the panel identify nozzle location and spray panel.

WARNING!!! Pressure washer produces fluid pressures and velocities high enough to penetrate human and animal flesh which could result in serious injury or amputation. Do not point pressure washer in direction of people or animals. High velocity fluid spray can cause objects to break, propelling particles at high speeds.

0° Nozzle - Red: This nozzle delivers a pinpoint stream of pressurized water and is extremely powerful. It covers only a small area of cleaning. This nozzle should only be directed at surfaces that can withstand high pressure such as metal or concrete. Do not use this nozzle to clean wood.

15° Nozzle - Yellow: This nozzle delivers a powerful 15 degree spray pattern for intense cleaning of small areas. This nozzle should only be used on areas and materials that can withstand high pressure.

25° Nozzle - Green: This nozzle delivers a 25 degree spray pattern for intense cleaning of larger areas. This nozzle should only be used on areas that can withstand the pressure.

40° Nozzle - White : This nozzle delivers a 40 degree spray pattern and a less powerful stream of water. This nozzle can cover a wide area and should be used for most general cleaning jobs

Chemical Nozzle - Black: This nozzle is used to apply special chemicals and cleaning solutions. This nozzle produces the weakest pressure stream of the five nozzles.

Interchanging Pressure Nozzles

Turn off pressure washer before attempting to change nozzles. Follow the steps below:

1. Pull slip ring of quick-disconnect back and remove pressure nozzle.
2. Flow the 13.1.3-5 process to insert the nozzle.

WARNING! Never place hands in front of nozzle. Never grasp hose or fittings during pressure washer operation. Never attempt to attach or remove spray wand or hose fittings while pressure washer system is pressurized.

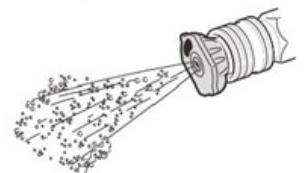
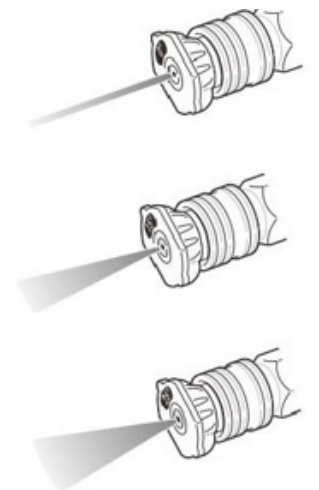
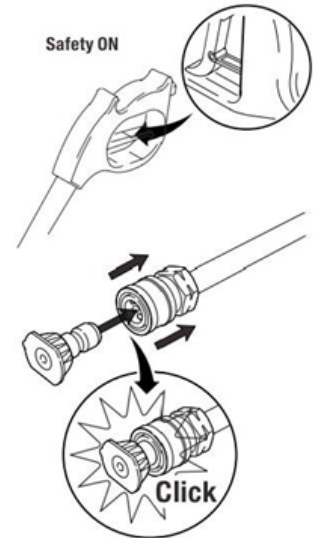

Adjusting Spray Pressure

Pressure Rinsing

1. Remove black spray tip from nozzle extension.
2. Select and install desired high pressure spray tip.
3. Keep spray gun a safe distance from area you plan to spray.
4. Increase (decrease) spray pressure by turning pressure control knob clockwise (counter-clockwise).
5. Apply a high pressure spray to a small area and then check surface for damage. If no damage is found, you can assume it is okay to continue rinsing.
6. Start at top of area to be rinsed, working down with same overlapping strokes as you used for cleaning

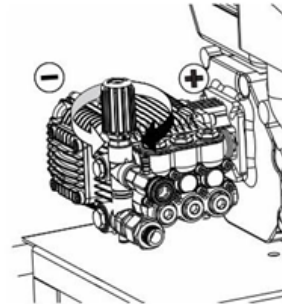

Using Chemicals & Detergents

NOTE: Use only detergents designed for pressure washers; household detergents, acids, alkalines, bleaches, solvents, flammable material, or industrial grade solutions can damage the pump. Many detergents may require mixing prior to use. Prepare cleaning solution as instructed on the solution bottle.

Set Up Procedure:

1. Attach the chemical hose onto the barbed fitting situated near the back of the high pressure hose connection.
2. Press the other end of the chemical hose (with the filter attached) into the container holding the chemicals or detergents you are using.
3. Attach the chemical nozzle onto the lance as shown previously.

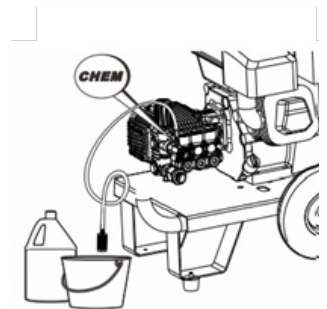

Chemical Cleaning:

1. Spray the chemicals onto a dry surface using the procedures outlined in previous sections. Start at the lower portion of the cleaning area and working upwards, using long, even, overlapping strokes.
2. Always ensure that the filter is fully submerged in the cleaning solution at all times.
3. Allow the detergent to soak in for 3-5 minutes before washing and rinsing.
4. Re-apply as needed to prevent the surface from drying. Do not allow the detergent to dry on to the cleaning surface to prevent streaking.

NOTE: Detergent cannot be applied with the high pressure spray tips (white, green, yellow or red)

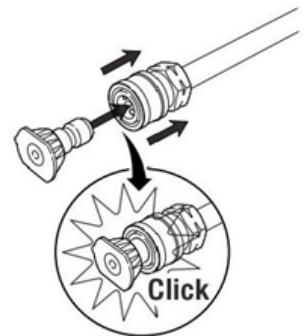

After Chemical Cleaning:

IMPORTANT: You will need to flush the detergent siphoning system after each use by placing the filter into a bucket of clean water then run the pressure washer in low pressure for 1-2 minute.

1. After using chemicals, soaps and detergents it is necessary to thoroughly clean the pressure washer
2. Place the chemical hose in a container of clean water
3. Turn on the pressure washer and hold the trigger on the spray gun top draw clean water through the system to clean it thoroughly

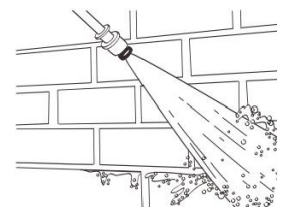

Maintenance

To ensure efficient operation and longer life of your pressure washer a routine maintenance schedule should be prepared and followed. If the equipment is used in unusual conditions such as high-temperature or dusty conditions more frequent maintenance checks will be required.

WARNING

Before performing any maintenance be aware that the equipment should be completely shut-down, de-pressurised and allowed to cool down. This will ensure that no injuries can be sustained by moving parts, water pressure or hot surfaces.

Engine contains flammable fuel do not smoke near or work near naked flames while maintaining this equipment.

Please note: All repairs should be carried out by Dealer approved engineers. All replacement parts should be supplied or recommended by the Dealer. Any unapproved repairs or modifications will invalidate the warranty.

Engine:

Check the engine regularly, replace oil, clean spark plugs and maintain parts as required.

Pump Oil:

Change the pump oil regularly. Change the pump oil after the first 30 hours of work and successively every 100 hours. In either case ensure that the oil is changed at least once a year. Check with your nearest Dealer for advice on the best Pump Oil to use with this equipment if you are unsure.

NOTICE: Avoid prolonged or repeated skin contact with used motor oil. Used motor oil has been shown to cause skin cancer in certain laboratory animals. Thoroughly wash exposed areas with soap and water.

Nozzle Tips:

If the nozzle becomes clogged with dirt and debris excessive pressure can build up.

If the nozzle becomes partially clogged or restricted the pump pressure will fluctuate and can become harmful and dangerous.

Clean the nozzle immediately and follow these instructions:

1. Shut-off the engine and turn off/disconnect the water supply.
2. Pull the trigger on the gun to relieve any water pressure.
3. Disconnect the lance from the gun.
4. Remove the nozzle from the lance - remove any obstructions with the nozzle cleaning tool and back flush with clean water.
5. Direct the water supply into the spray wand end to back flush loosened particles for 30 seconds.
6. Reassemble the nozzle onto the lance.
7. Reconnect the lance to the gun and turn on the water supply.
8. Start the washer pump and place the lance into the high pressure setting to test.

Nozzle Cleaning Pin

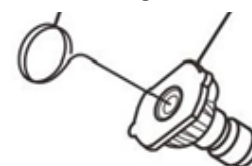

Cleaning The Water Filter:

The water filter should be checked regularly and cleaned if necessary:

1. Remove the filter by grasping the end and removing it from the water inlet on the pump.
2. Clean the filter by flushing it with water on both sides.
3. Re-insert the filter in the water inlet on the pump.



Water Filter In-place

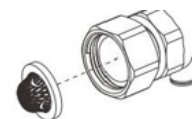

Water Filter Removed

High Pressure Hose:

Replace the high pressure hose when the hose have any of the below circumstance:

1. Cover damage.
2. Burst.
3. Bubbles / blisters.
4. Kinked / collapsed

WARNING! The high pressure stream of water can cut through skin and its underlying tissues, leading to serious injury and possible amputation. Never repair high pressure hose. Replace it. Replacement hose rating **MUST** exceed maximum pressure rating of the unit.

Cleaning the Fuel Tank Filter:

The fuel tank filter should be removed and cleaned after every 150 hours of running or every 3 months using an environmentally friendly water-based de-greasing agent. Refit when clean.

Maintenance Schedules (Petrol Engine)

Item:	Task Description	Each Use	1st Month 20hrs	Each Season 50Hrs	Every 6 Months 100hrs	Every Year 300hrs
<u>Engine Oil:</u>	Oil Level Check	X				
	Replace		X		X	
<u>Reduction Gear Oil (If Applicable)</u>	Oil Level Check	X				
	Replace		X		X	
<u>Air Cleaner Filter</u>	Check	X				
	Clean			XX	XX	
	Replace					XXX
<u>Deposit Cup</u>	Clean				X	
<u>Spark Plug</u>	Clean Adjust				X	
	Replace					X
<u>Spark Eliminator</u>	Clean				X	
<u>Idling</u>	Check Adjust					X
<u>Valve Clearance</u>	Check Adjust					X
<u>Fuel Tank filter</u>	Clean					X
<u>Fuel Tank Line</u>	Check	Check with your Dealer for advice if any problem are detected				

X = Only for inside ventilating double core carburetors

XX = Repeat task more often than scheduled if equipment is used in dusty working environments

0 = Only for paper core cleaners

00 = Maintenance to be carried out by Dealer approved technician

Storage

After General / Regular Use

1. Drain all water from the high pressure hose, coil it and hang on the cradle on the petrol washer frame. If chemicals were used ensure the pump and chemical hose are thoroughly cleaned out.
2. Drain all the water from the gun and lance by holding the gun in a vertical position with the nozzle end pointing down and squeeze the trigger. Store in the gun / hose holder

Storage cont

Preparation for Winter and Long-term Storage

Note: It is recommended that you follow these steps to protect the internal seals of the pump when storing the equipment for more than 30 days and or when, freezing temperatures are expected.

1. Obtain a funnel, 200ml of antifreeze and approximately 1M of garden hose with a male hose connector attached to one end.
2. Disconnect the spark plug wire.
3. Connect the hose to water inlet on the pump.
4. Pour the antifreeze into the hose via the funnel.
5. Pull the engine starter cord slowly several times until antifreeze comes out of the high pressure water hose connection on the pump.
6. Remove the short hose from the water inlet on the pump.
7. Reconnect the spark plug wire.

Long Term Storage Instructions (DIESEL ENGINE)

Follow the instructions below if you plan to storing the Diesel engine for a long periods of time.

1. Run the engine for 3 minutes to burn out the excess fuel in the chamber.
2. Stop the engine. Drain the engine lube oil while the engine is still warm and refill it with the new oil.
3. Remove the rubber plug on the rocker arm and put about 2cc of the lubricant into it, put it back in place
4. Recoil starting. Push the decompression lever down and hold it while you pull the recoil starter 2 or 3 times. (Do not start the engine).
5. Electric starting. Hold down the decompression lever and turn the start key switch to the START position. Let the engine rotate for about 2-3 seconds.
6. Pull the decompression lever up and pull the recoil starter slowly until you feel resistance. The resistance point occurs on the compression stroke where the intake and exhaust valves are closed. It is also the will prevent moisture from entering the chamber to cause rust.
7. Wipe the oil and dirt from the engine.

Decompression Lever

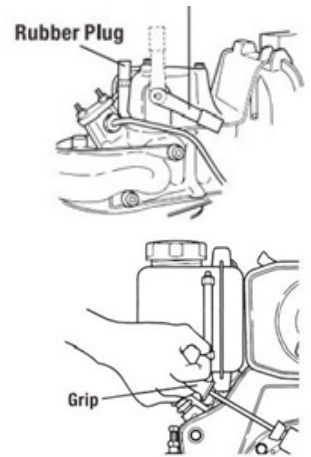

Service After Storage (Petrol Engine)

Before reusing the equipment after storage,you should carry out the following to keep the equipment in good condition.

Storage Time	Service Tank
Within one month	No Service required
Within one-two months	Drain out existing fuel out of the fuel tank and refill with fresh fuel
Two months - one year	Drain out existing fuel out of the fuel tank and refill with fresh fuel Drain the fuel out of carburetor Empty the deposit cup
Over a year	Drain out existing fuel out of the fuel tank and refill with fresh fuel Drain the fuel out of carburetor Empty the deposit cup Close the fuel valve and wait for engine to stop

Trouble shooting

PROBLEM	PROBABLE CAUSE	SOLUTION
Engine shuts down when running.	<ol style="list-style-type: none"> 1.Out of fuel. 2.Low Engine Oil 	<ol style="list-style-type: none"> 1.Fill fuel tank. 2. Add oil.
Engine will not start; or starts and runs rough.	<ol style="list-style-type: none"> 1.Rocker switch set to "OFF" position. 2.Fuel valve is in "OFF" position. 3.Dirty air cleaner 4.Out of fuel. 5.Stale fuel. 6.Spark plug wire not connected to spark plug. 7.Bad spark plug. 8.Water in fuel. 9.Flooded. 10.Excessively rich fuel/air mixture. 11.Intake valve stuck open or closed. 12.Engine has lost compression. 13.Low engine oil. 14.Wrong Fuel. 15.Engine is too hot 16.Chock is in wrong position 17.Pressure Builds up after 2 pulls on recoil starter or after initial use. 	<ol style="list-style-type: none"> 1.Set switch to "ON" position. 2.Turn fuel valve to "ON" position. 3.Clean or replace air cleaner 4.Fill fuel tank. 5.Drain fuel tank and carburetor; fill with fresh fuel. 6.Connect wire to spark plug. 7.Replace spark plug. 8.Drain fuel tank and carburetor; fill with fresh fuel. 9.Wait 5 minutes and re-crank engine. 10.Contact authorized service facility. 11.Contact authorized service facility. 12.Contact authorized service facility. 13.Add oil. 14.Use recommended fuel. 15.Allow engine to cool 16.Change chock position 17.Squeeze gun trigger to relieve pressure.
Engine "Hunts" or falters.	<ol style="list-style-type: none"> 1.Carburetor Is running too rich or too lean. 	<ol style="list-style-type: none"> 1.Contact authorized service facility.
Engine lacks power.	<ol style="list-style-type: none"> 1.Cylinder pressure is low. 2.Dirty air cleaner 	<ol style="list-style-type: none"> 1.Contact authorized service facility. 2.Replace air filter.
Starter motor operates but DIESEL engine does not start	<ol style="list-style-type: none"> 1. No diesel fuel 2. Improper diesel fuel 3. Clogged fuel filter 4. Poor fuel injection 5. Compressed air leakage from intake/exhaust valves 	<ol style="list-style-type: none"> 1. Refuel fuel system 2. Replace with recommended diesel fuel 3. Replace fuel filter 4. Contact authorized service facility. 5. Contact authorized service facility.
Starter motor does not operated or rotates too slowly (DIESEL engine can be turned manually)	<ol style="list-style-type: none"> 1. Battery needs charging 2. Faulty cable connection at battery terminals 3. Faulty starter switch 4. Faulty starter motor 	<ol style="list-style-type: none"> 1. Check electrolyte, recharge 2. Clean terminals, retighten 3. Contact authorized service facility. 4. Contact authorized service facility.
Black exhaust smoke (DIESEL engine)	<ol style="list-style-type: none"> 1. Engine overloaded 2. Clogged air cleaner element 3. Improper diesel fuel 4. Faulty spraying of fuel injection 5. Excessive intake/exhaust valve clearance. 	<ol style="list-style-type: none"> 1. Reduce load 2. Clean element or replace 3. Replace with the recommended diesel fuel 4. Contact authorized service facility. 5. Contact authorized service facility.
White exhaust smoke (DIESEL engine)	<ol style="list-style-type: none"> 1. Improper diesel fuel 2. Faulty spray pattern of fuel injection 3. Fuel injection timing delay 4. Engine burning oil 	<ol style="list-style-type: none"> 1. Replace with the recommended diesel fuel 2. Contact authorized service facility. 3. Contact authorized service facility. 4. Contact authorized service facility.

Trouble shooting

PROBLEM	PROBABLE CAUSE	SOLUTION
No pressure or Low pressure.	<ol style="list-style-type: none"> 1.Spray wand not set to high pressure. 2.Lower water supply. 3.Hose fitting leaks during high pressure. 4.Nozzle obstructed. 5.Water filter screen obstructed. 6.Defective thermal relief valve. 7.Air in hose. 8.Choke lever in choke position. 9.Throttle control lever is hot in fast position. 10.High pressure too long. 	<ol style="list-style-type: none"> 1.See "Using Spray Wand" section. 2.Water supply must be 5 GPM @ 20 psi. 3.Tighten hose fitting. Use thread sealant tape if necessary. 5.Remove and clean filter. 6.Call Customer Service: 7.Stop engine and water source. Disconnect water source from pump inlet and turn water source to ON to remove all air from hose. When steady stream of water is present, turn water source to OFF. Re-connect water source to pump inlet and turn on water source. Squeeze trigger to remove remaining air. 8.Move choke to NO CHOKE position. 9.Move throttle control lever from fast position. 10.Use High pressure hose under 100 ft (30M).
No or low pressure (after period of normal use).	<ol style="list-style-type: none"> 1.Worn seal or packing. 2.Worn or obstructed valves. 3.Worn unloader piston. 4.Worn E-Z start valve. 	Have parts cleaned or replaced by authorized dealer.
Pump will not draw Chemicals	<ol style="list-style-type: none"> 1.Spray wand not set to low pressure.. 2.Chemical filter clogged. 3.Chemical screen not in chemical. 4.Chemical solution too thick. 5.Pressure hose too long 6.Chemical build-up in chemical injector. 	<ol style="list-style-type: none"> 1.See "Using Spray Wand" section. 2.Clean Filter. 3.Ensure end of chemical hose is fully submerged into chemicals. 4.Dilute chemical. Chemical solutions should have same consistency as water. 5.Lengthen water supply hose instead of pressure hose. 6.Have parts cleaned or replaced by authorized dealer.
Water leaking at pump.	<ol style="list-style-type: none"> 1.Loose connections. 2.Piston packings worn. 3.Worn or broken O-rings. 4.Pump head or tubes damaged from freezing. 	<ol style="list-style-type: none"> 1.Check and replace O-ring 2.Tighten hose connection. 1.Tighten connections. 2.Have parts cleaned or replaced by authorized dealer. 3.Have parts cleaned or replaced by authorized dealer. 4.Have parts cleaned or replaced by authorized dealer.
Water leaking at spray gun/spray wand connection.	<ol style="list-style-type: none"> 1.Worn or broken O-ring. 2.Loose hose connection. 	<ol style="list-style-type: none"> 1. Check and replace O-ring. 2. Tighten hose connection.
Oil Leaking At Pump And Or Gearbox	<ol style="list-style-type: none"> 1.Oil seals worn. 2.Loose drain plug. 3.Worn drain plug O-ring. 4.Worn fill plug O-ring. 5.Pump overfilled. 6.Incorrect oil used. 7.Vent plug clogged. 	<ol style="list-style-type: none"> 1. Have parts cleaned or replaced by authorized dealer. 2.Tighten drain plug. 3.Inspect and replace O-ring. 4.Inspect and replace O-ring. 5.Check for correct amount. 6.Drain and refill with correct type and amount of oil. 7.Cleanvent plug. Use air hose to free it of blockage. If problem persists, replace vent plug.
Pump pulsates	Nozzle obstructed.	See "Using Spray Wand" section.

Pressure Washer Exploded View & Parts List

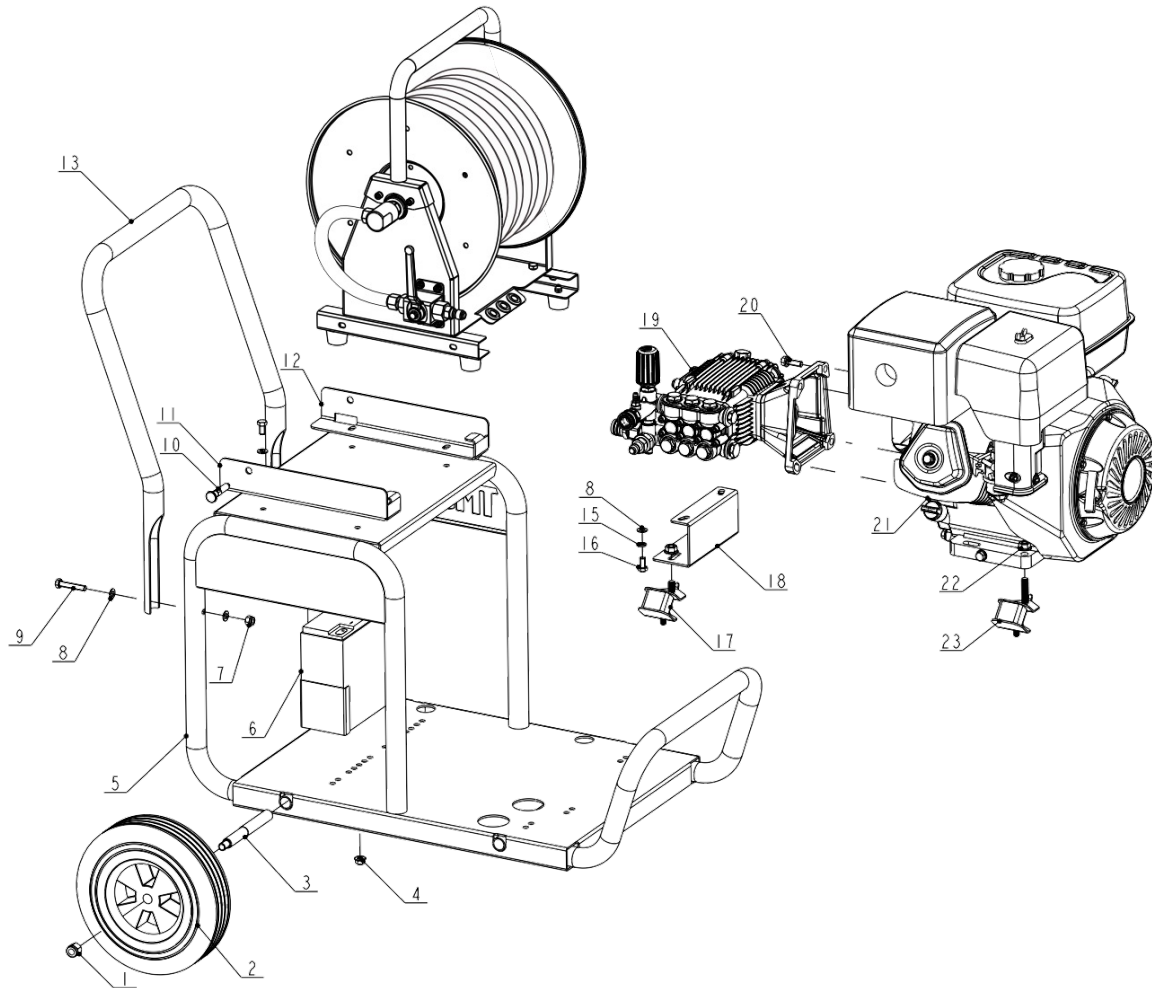

No. Description

- 1. Nut, Axle
- 2. Wheel
- 3. Axle
- 4. Nut M8
- 5. Frame
- 6. Battery 12V/20AH
- 7. Nut M8
- 8. Washer D8
- 9. Bolt M8x25
- 10. Locking Pin M10x25
- 11. Mounting Base Right
- 12. Mounting Base Left

No. Description

- 13. Handle
- 14. Hose Reel ASSY
- 15. Washer D8
- 16. Bolt M8x16
- 17. Anti-Vibration Feet M10x20
- 18. Pump Bracket
- 19. High Pressure Pump
- 20. Bolt M8x25
- 21. Engine
- 22. Nut M10
- 23. Anti-Vibration Feet M10x45

Triplex Pump Exploded View & Parts List

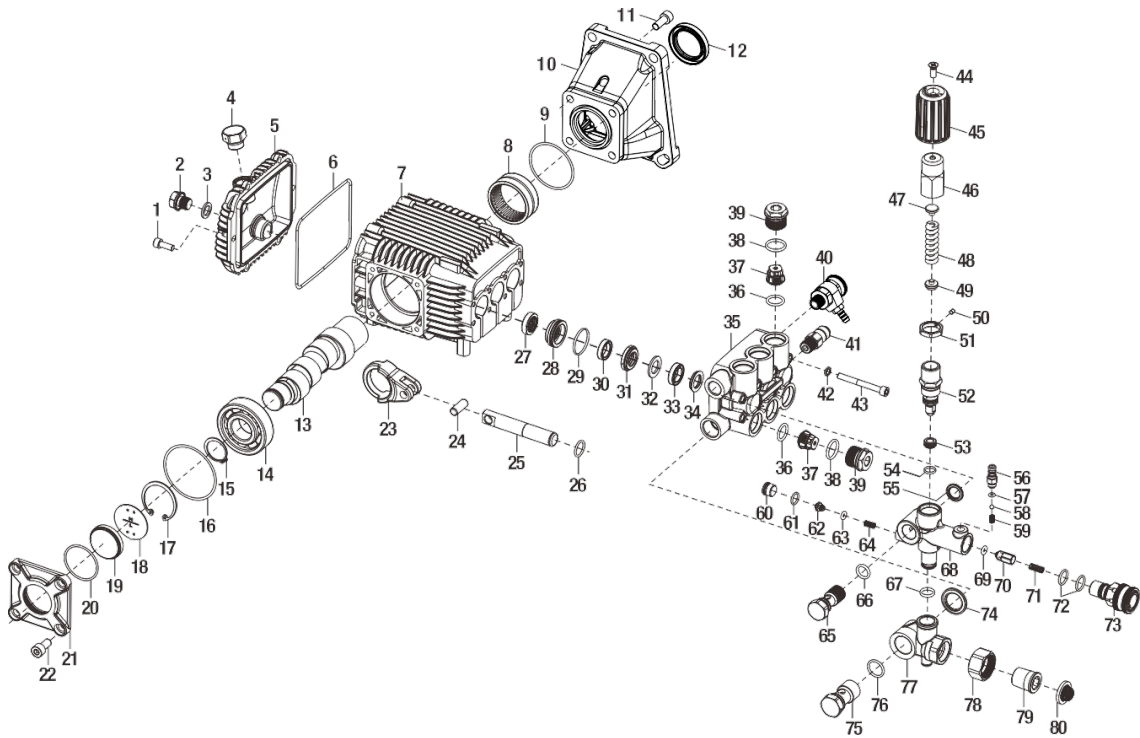

NO.	DESCRIPTION	NO.	DESCRIPTION	NO.	DESCRIPTION
1.	Bolt, crankcase cover	28	Locating ring	55.	Gasket, unloader valve housing
2	Oil drain plug	29	O-ring, locating ring	56	Detergent injector fitting
3	O-ring, oil drain plug	30	Low pressure water seal	57	O-ring, injector fitting
4	Vented oil cap	31	Compression ring	58	Ball, injector fitting
5	Crankcase cover	32	Compression flake	59	Spring, injector fitting
6	Gasket, crankcase cover	33	High pressure water seal	60	Plug, easy start
7	Crankcase	34	Supporting ring	61	O-ring, plug, easy start
8	Needle bearing	35	Manifold	62	Valve core, easy start
9	O-ring, flange	36	O-ring, checking valve	63	O-ring, valve core, easy start
10	Flange	37	Checking valve assy	64	Spring, easy start
11	Bolt, flange	38	O-ring, valve cap	65	Water outlet banjo bolt
12	Oil seal, flange	39	Checking valve cap	66	O-ring, outlet banjo bolt
13	Crankshaft	40	Outlet plug, manifold	67	O-ring, unloader valve housing
14	Ball bearing	41	Thermal relief valve	68	Unloader valve housing
15	Scrap ring	42	Washer	69	O-ring, outlet checking valve
16	O-ring, crankshaft cover	43	Bolt, manifold	70	Outlet checking valve
17	Retain ring	44	Screw, knob cap	71	Spring, outlet checking valve
18	Oil level plate	45	Plastic knob cap	72	O-ring, outlet fitting
19	Oil sight glass	46	Pressure adjusting knob	73	Quick disconnect outlet fitting
20	O-ring, oil sight glass	47	Upper seat, adjusting spring	74	Gasket bypass housing
21	Crankshaft cover	48	Pressure adjusting spring	75	Water Inlet banjo bolt
22	Bolt, crankshaft cover	49	Spring seat	76	O-ring, inlet banjo bolt
23	Connecting rod	50	Screw, jam nut	77	Bypass housing
24	Pin	51	Pressure jam nut	78	Swivel nut, inlet connector
25	Ceramic coating plunger	52	Unloader valve assy	79	Body, inlet connector
26	O-ring	53	Valve seat	80	Filter washer, inlet connector
27	Oil seal, plunger	54	O-ring, valve seat		

Gearbox Exploded View & Parts List

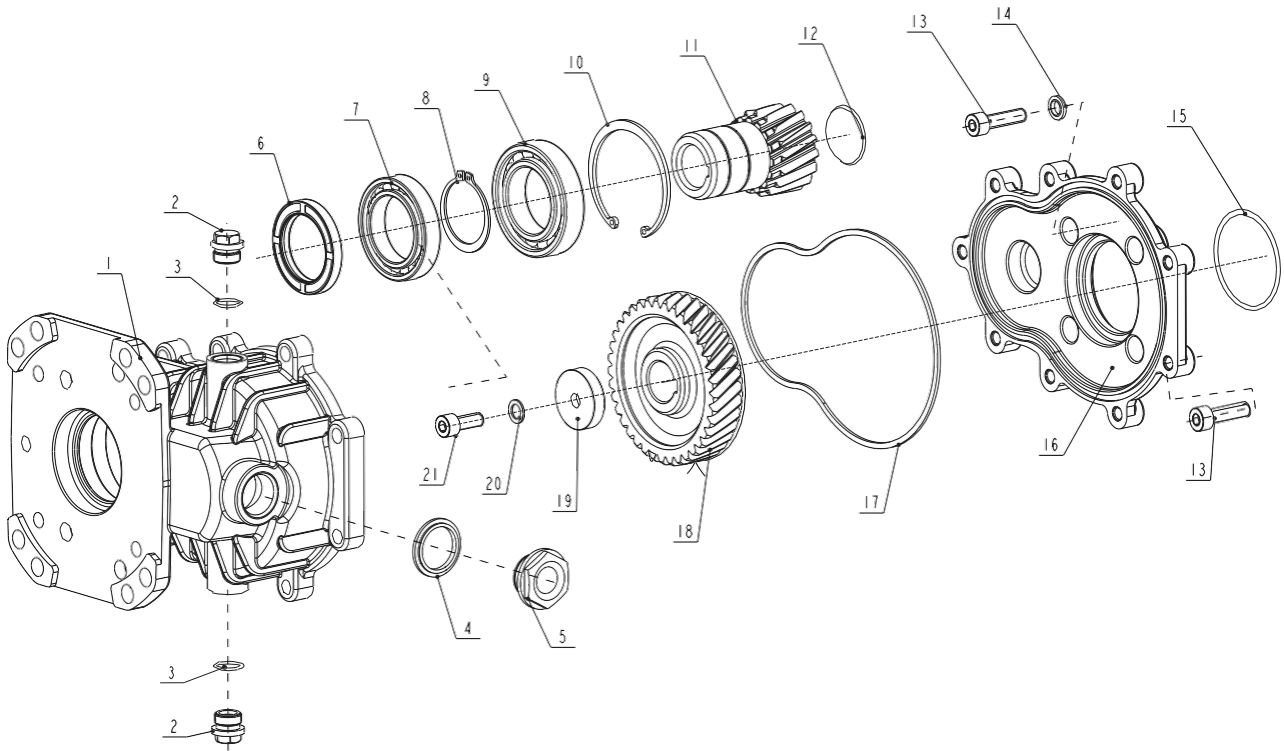

- NO. DESCRIPTION**
- 1. Gearbox Case
 - 2. Oil Plug
 - 3. O-ring 14.2*1.9
 - 4. Gasket Oil Gauge
 - 5. Sight Gauge
 - 6. Oil Seal
 - 7. Ball Bearing 61908

- NO. DESCRIPTION**
- 8. Snap Ring D40
 - 9. Ball Bearing 6008
 - 10. Snap Ring D68
 - 11. Engine Gear
 - 12. Blocking Flake
 - 13. Bolt M8*30
 - 14. Combine Washer

- NO. DESCRIPTION**
- 15. O-ring 55.25*2.62
 - 16. Gearbox Cover
 - 17. Gasket Cover
 - 18. Pump Gear
 - 19. Ring
 - 21. Washer 08
 - 22. Bolt M8*20

EC Declaration of Conformity

We, Jefferson Professional Tools & Equipment, as the authorised European Community representative of the manufacturer, declare that the following equipment conforms to the requirements of the following:

**JEFWASPGR130HP-PT**

2014/30/EU Electromagnetic Compatibility Directive	EN 55012:2007+A1:2009
2006/42/EC Machinery Directives	EN 1679-1:1998+A1:2011, EN 60335-1:2012+A15:2021, EN 60335-2-79:2012, EN 1679-1:1998+A1:2011,

Notified Testing Body:

TÜV AUSTRIA (SHANGHAI) CO., LTD.
Room 12D, Orient Century Building, No. 345 Xian Xia Road,
Shanghai, P/C 200336, P.R.China.

JEFWASPGR090HP-DL

2006/42/EC Machinery Directives	EN 1679-1:1998+A1:2011 EN 60335-2-79:2012 EN ISO 12100:2010
---------------------------------	---

Notified Testing Body:

Handzhou ORD Certification Technology Service Co. Ltd,
Room 401, Jinsha Century Building, Qiantang Area, Hangzhou City,
Zhejiang Province, China.

Guaranteed LWA:**Diesel: 111dB****Petrol: 100dB****Product Name:**

JEFFERSON PETROL / DIESEL GEARBOX WASHER

Product Codes:

JEFWASPGR090HP-DL JEFWASPGR130HP-PT

Signed:

Stephen McIntyre
Operations Manager

Date:

20th June 2024

Name and address of manufacturer or authorised representative:

Jefferson Professional Tools & Equipment
24 Lisgorgan Lane,
Upperlands,
BT46 5TE

Tel: +44 (0)1244 646 048 (UK)
+353 (0)1473 0300 (ROI)

Email: info@jeffersonstools.com

Jefferson[®]
PROFESSIONAL TOOLS & EQUIPMENT

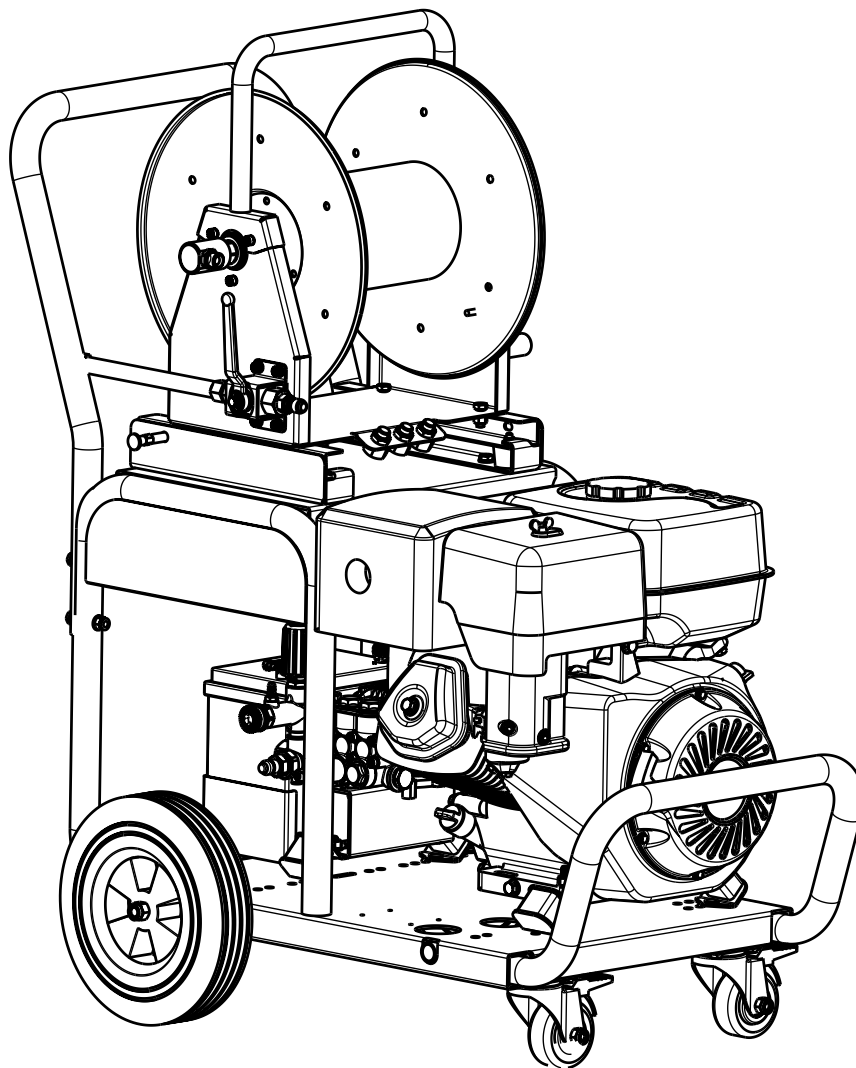

Jefferson[®]
PROFESSIONAL TOOLS & EQUIPMENT

Jefferson Professional Tools & Equipment
24 Lisgorgan Lane, Upperlands, BT46 5TE

Tel: +44 (0)1244 646 048 (UK)
+353 (0)1473 0300 (ROI)

Email: info@jeffersonstools.com