

Jefferson Adjustable Work Table CW x1 Drawer - JEFTBL05-01

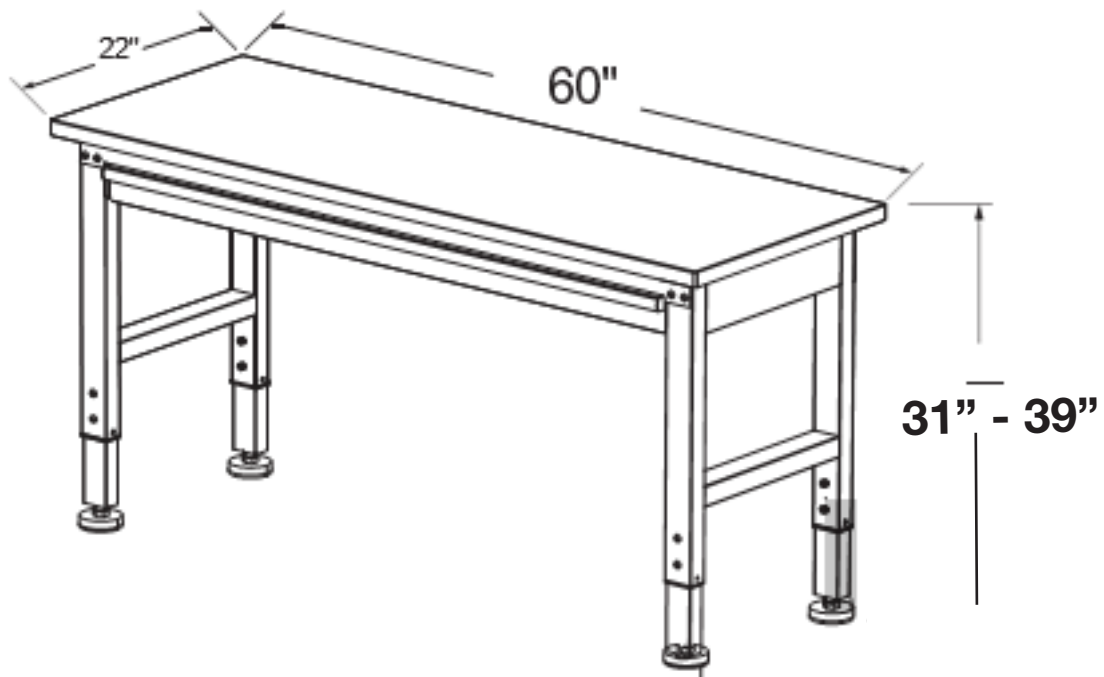

USE PRECAUTION
For your safety



**INSTRUCTION
MANUAL**
Read and understand



EYE PROTECTION
Must be worn









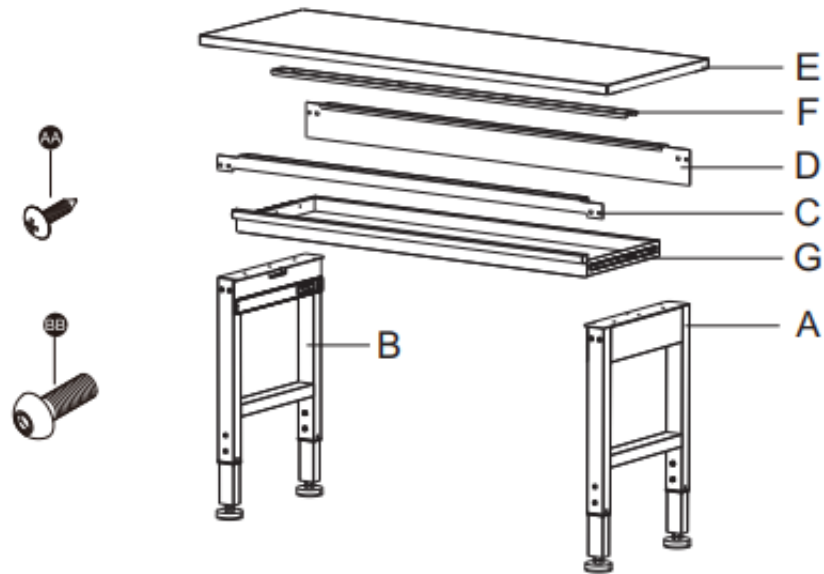

PROTECTIVE GLOVES
Must be worn when
handling tool

SAVE THIS MANUAL FOR FUTURE REFERENCE

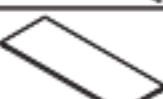
Components:



PART	PIC	DESCRIPTION	QTY
A		Right leg	1
B		Left leg	1
C		Front beam	1
D		Back beam	1
E		Rubber wood top	1
F		Support rod	1
G		Drawer	1
AA		#5x15mm Phillips head self tapping screw	28
BB		M8x20mm Inner hexagonal at head bolt	8

TOOLS REQUIRED (NOT INCLUDED):



PH2
Screwdriver



13mm
Spanner



19mm
Spanner



5mm
Hex Key

Assembly:

NOTE: Do not tight all the screws before final step.

Step 1.

Fix the leg (A) (B) with beam (C) (D) use 8 pcs 8M x 20 bolts (BB)

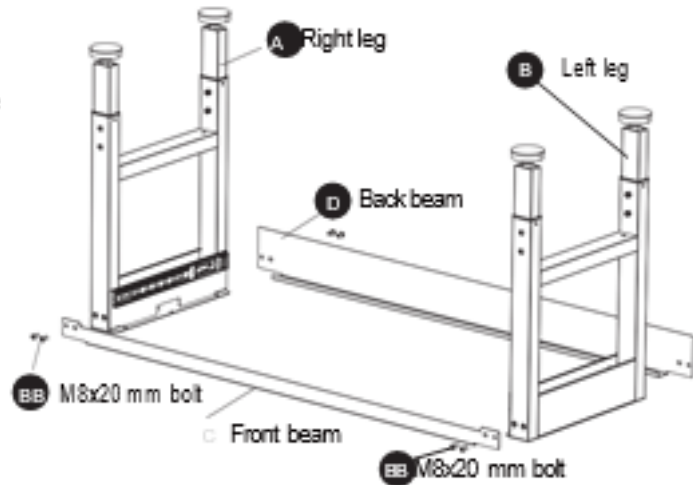
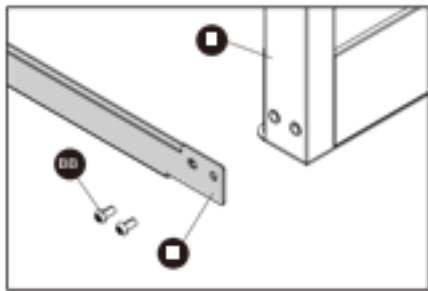

PART	A	B	C	D	BB
DESCRIPTION	Right leg	Left leg	Front beam	Back beam	M8x20 mm bolt
QTY	1	1	1	1	8

Step 2

Place the rubber table top (E) on a flat surface with the positioning label facing up. Protect the table with packaging materials.

Align the positioning label and install the legs (A&B) & beams (C&D) on the rubber wood top using 26 pcs #5x15 mm screws (AA).

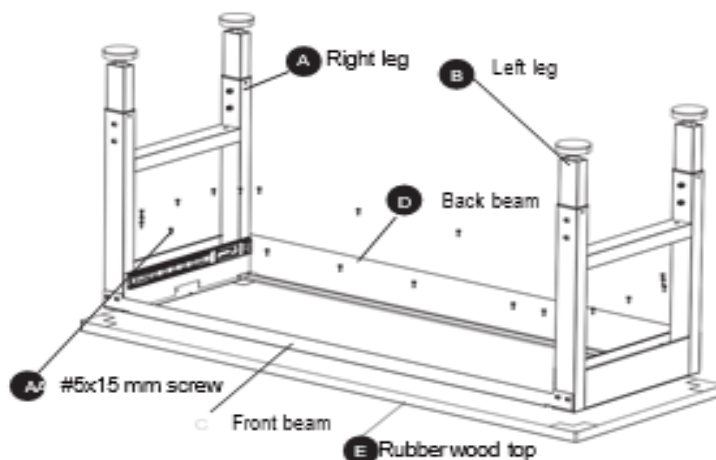
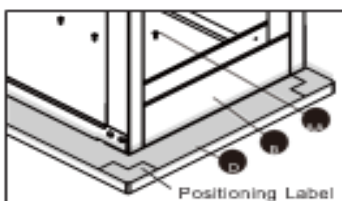
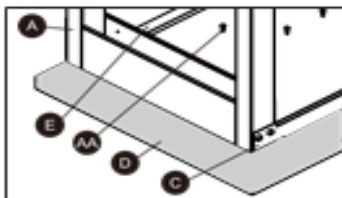

PART	A	B	C	D	E	AA
DESCRIPTION	Right leg	Left leg	Front beam	Back beam	Rubber wood top	#5x15 mm screw
QTY	1	1	1	1	1	22

Step 3

Fix the support rod (F) on the shaft of the rubber wood top (E) using 6 pcs #5x15 mm screws (AA).

NOTE: the support rod (F) fixed on the wood to prevent deformation of the wood, not fix on the legs (A&B)

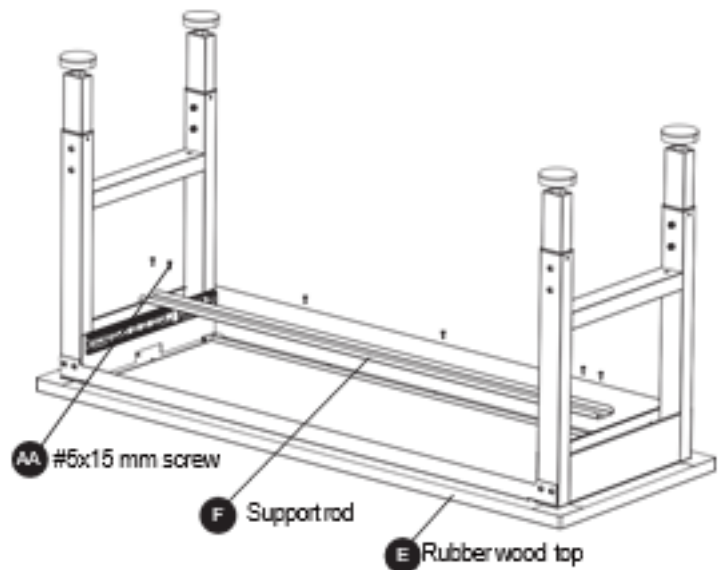
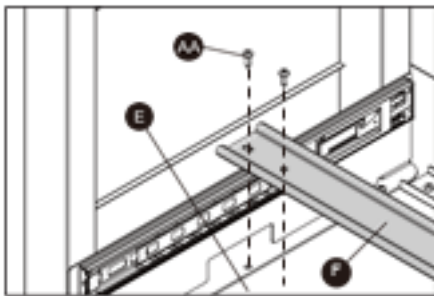

Step 4

Inserting the drawer: Pull the slides and slide carrier out until fully extended. Hold the slide on the drawer while aligning it with the slide on the plate. Slightly insert one side and repeat for the other side. Slowly push the drawer until it is fully closed to engage slide.

Removing the drawer: Fully empty and extend the drawer. Push up the release lever on the left drawer slide while pulling down the other release lever. Pull the drawer outward until it is released from the slides.

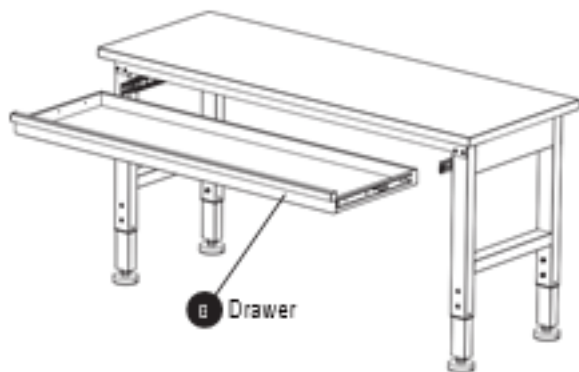
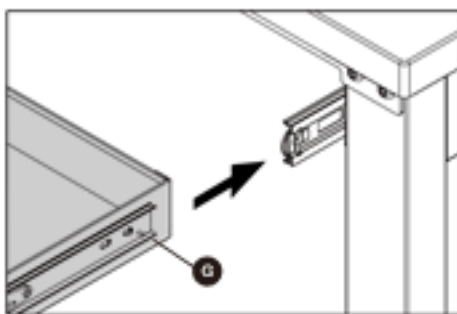

PART	G
DESCRIPTION	Drawer
QTY	1

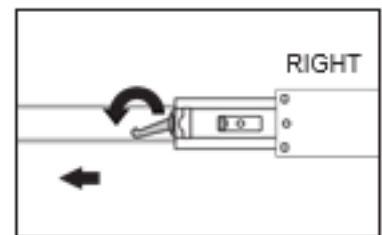
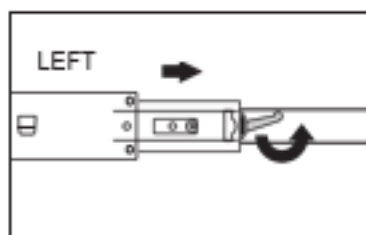

Step 5

Stand up the workbench and adjust the feet if necessary to make the workbench stable

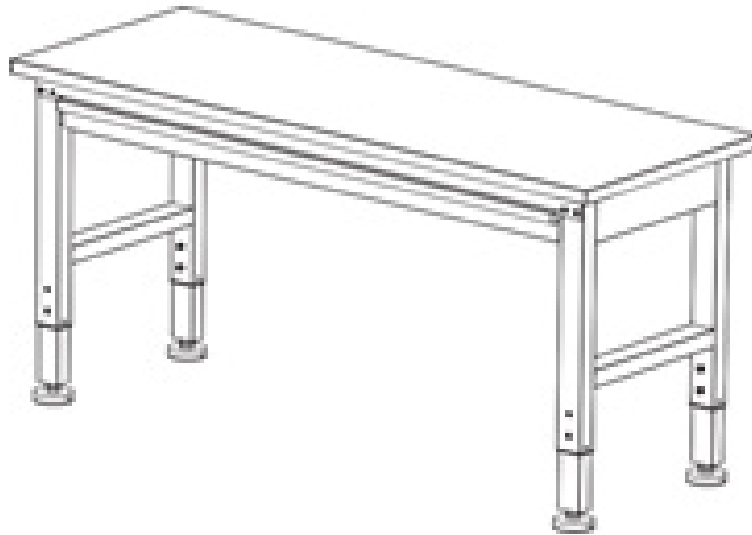

Disposal:

Please recycle where facilities exist. Check with your local authority for recycling advice.