



400KG POWER HOIST

JEFPOWH400

User Manual

v.1.1

**UK
CA**

CE

RoHS



Please read and ensure that you understand all of the operating instructions, safety precautions and warnings in this user guide before operating or maintaining this equipment. Keep a copy of this user guide with the equipment for future reference.



An accident can often be avoided by recognizing a potentially hazardous situation before it occurs, and by observing appropriate safety procedures. Never use this equipment or modify it for any other use other than that which it has been designed to perform.



Contact Jefferson Tools for all information relating to the repair and maintenance of this equipment. Contact a qualified electrician for advice on any issues relating to electrical safety in your working environment.

EQUIPMENT OVERVIEW

- Compact, general purpose electric power hoist
- Fitted with a powerful 950W Motor
- Ideal for all manner of lifting work
- Strong Ø3.8mm x 12M twist-free cable
- 200kg (Single) or 400kg (Double) lifting capacity
- Easy to install & supplied with fixing clamps for fitting the hoist on square box section beams
- Includes remote control for convenient operation
- Approved and tested to EU and UK Lifting Gear Regulations

SPECIFICATIONS

Model Number:	JEFPOWH400
Load Capacity:	200kg • 400kg
Lifting Height:	12M • 6M
Lifting Speed:	10M / Min • 5M / Min
Cable Diameter / Length:	Ø3.8mm x 12M
Voltage ~ Frequency:	230V ~ 50Hz
Input Power:	950W
Ingress Protection:	IP54
Insulation Class:	B
Weight:	17kg



EQUIPMENT IDENTIFICATION

The key parts and features of the power hoist are indicated in Fig.1 and identified in the table below:

1	Fixing Clamps
2	950W Motor
3	Power Cable
4	BS1363/A 13 Amp UK 3-Pin Plug
5	Remote Control Handle
6	Lift-Lower Control Switch
7	Emergency Stop Button
8a	Lifting Hook
8b	Hook Safety Bar
9	Cable Block
10	Ø3mm x 12M Cable
11	Limit Frame
12	Cable Roll

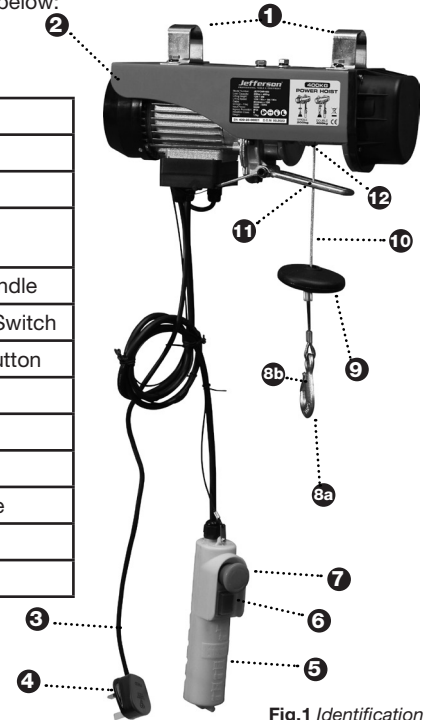

Fig.1 Identification

EQUIPMENT SAFETY

The following safety guidelines will help to ensure safe use of this equipment:

- This hoist should only be operated by competent and trained individuals who have read this user guide and who have a thorough knowledge of the safe operation of the equipment.
- The hoist should be installed in a dry work location free from frost and low temperatures and explosive materials.
- Ensure adequate lighting and maintain a clean debris-free work area.
- Do not leave the hoist connected to the mains supply when not in use and keep children away from the work area at all times.
- Never attempt to exceed the rated lifting capacity indicated on the hoist's specification plate and in this user guide.
- If the equipment is unable to hoist a load, do not continue pressing the hoisting button: this means that the load exceeds the machine's maximum capacity.
- Do not use two or more electric hoists to lift one item.
- Do not lift heavy items aslant; do not use the electric hoist to drag items along the ground.
- Do not attempt to lift or pull fixed or stationary items.
- Never stand under a hoisted loads.
- Never wrap the hoist cable around the load.
- Never allow a raised and supported load to fall and thus shock load the mounting, hoist, cable and hook.
- Do not attempt to lift angled loads or to drag loads with the hoist.
- The centre of gravity of the load must always be directly below the hoist.
- Do not attempt to carry out maintenance on the hoist while it is running or while it is connected to the power supply.
- For indoor use only! Do not use outdoors or in stormy weather conditions where power-outages are a risk.
- Never operate the hoist if you are tired, under the influence of medication, drugs or alcohol. Never use the hoist to lift another person. Never use the hoist to lift dangerous materials.

ELECTRICAL SAFETY

Ensure that you check the equipment thoroughly to ensure it is safe and fit for purpose before each use. It is important that you inspect all plugs, sockets, power cables and electrical fittings for wear and damage and repair or replace any defective components. The risk of electric shock can be minimised by the correct use of the appropriate electrical safety devices. We recommend that you fit a Residual Current Circuit Breaker (RCCB) in the main distribution board and that a Residual Current Device (RCD) is used when operating this equipment.

The Electricity at Work Act 1989 includes legislation that places legal implications on employers to ensure the safety of electrical devices in the workplace. The regulations dictate that all portable equipment must be inspected regularly and tested to ensure that it is safe for use. 'Portable equipment' means any electrical item that can be moved and this is often referred to as Portable Appliance Testing (PAT). PAT testing should be carried out regularly on this equipment by trained, authorised personnel, as required by the legislation.

The Health and Safety at Work Act 1974 states that it is the responsibility of the owner of electrical appliances to ensure that both the equipment and working environments are maintained to ensure safe operation at all times. Check that all equipment power cables are secure, correctly insulated, free from damage, and protected against short circuit and overload before connecting to the power supply. Do not use worn or damaged cables, plugs, sockets or other fittings.

This equipment is supplied with a BS1363/A UK 13 Amp 3-Pin plug. Ensure that the power supply matches the voltage requirements specified on the equipment and that the plug is wired correctly and fitted with the correct fuse. If the electrical fuse blows, ensure it is replaced by an identical type of fuse with the same rating. (See Fig.2)

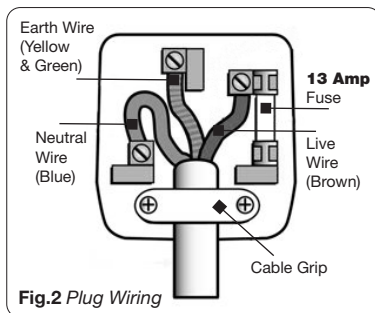

Fig.2 Plug Wiring

Ensure the power cable is kept away from heat, oil and sharp edges. We recommend that the equipment is connected directly to the power supply without the use of extension leads as the resulting voltage drop can reduce motor performance.

Always disconnect the equipment from the power source before servicing, inspecting, maintaining, cleaning, replacing or checking any parts.

INSTALLATION

The hoist is fitted with a specially designed bracket system that allows it to be fitted to a suitably sized square box section beams as shown in (Fig.3 below).

The hoist can be configured with a single or double cable setup depending on the weight of load you need to lift.

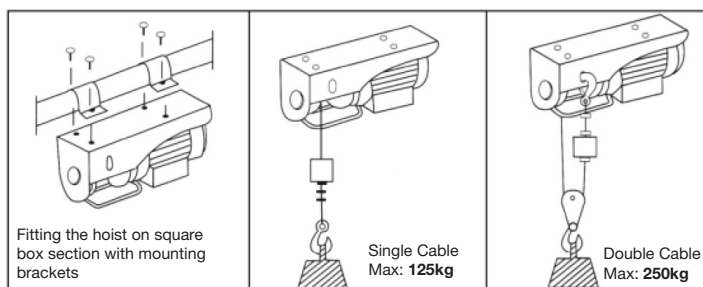

Fig.3 Installation

OPERATION GUIDE

BEFORE LIFTING:

Before beginning to operate the machine, ensure that the steel cable is correctly wound on the spool and the pitch is equal to the cable diameter. Leave at least 3 complete windings of cable on the hoist, to avoid damage to the cable fixing. (See Fig.4).

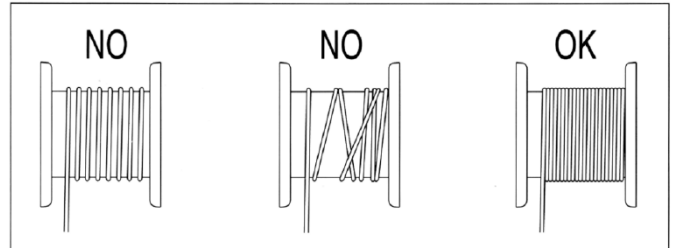

Fig.4 Correct Cable Spool Winding

Press the lift button before loading to eliminate any slack in the steel rope, before lifting the load. Avoid winding over 15m of cable on the hoist.



IMPORTANT: In an emergency press the emergency stop button to halt the hoist. To release the emergency stop button, turn it clockwise.

LIFTING:

1. Ensure that the load to be lifted is directly below the hoist and that any lifting straps, ropes or chains being used are capable of supporting the weight.
2. With mains power switched on, operate the Lift-Lower Control Switch to bring the hook to load height. Press the lower half of the control switch to lower hook and upper half to raise hook. Release the control switch to stop hoist.
3. Attach the lifting hook to the load, ensuring that safety bar is fully closed.
4. Use the control switch to raise or lower the load to the required height.

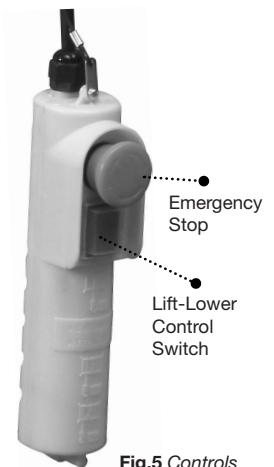

Fig.5 Controls

DOUBLE LINE LIFTING:

To carry out a double line lift, first hook the single line hook in the hoist aperture. Then take the double line pulley and hook, remove the 'R' pin, shaft and washers and undo nyloc nuts and remove the small bolts. Place the pulley on the cable loop between the hoist drum and single line hook. Replace hook and refit shaft, washers and 'R' pin, then refit small bolts and tighten the nyloc nuts on them.

Ensure that pulley is free to rotate. Proceed with the lifting procedure outlined above.



IMPORTANT: In order to prevent the motor/gearbox from overheating, the hoist should not be operated for longer than four minutes at any one time. Any period of use should be followed by a similar period with the hoist at rest.

Do not wind loose cable onto the drum - ensure that cable is always under tension.

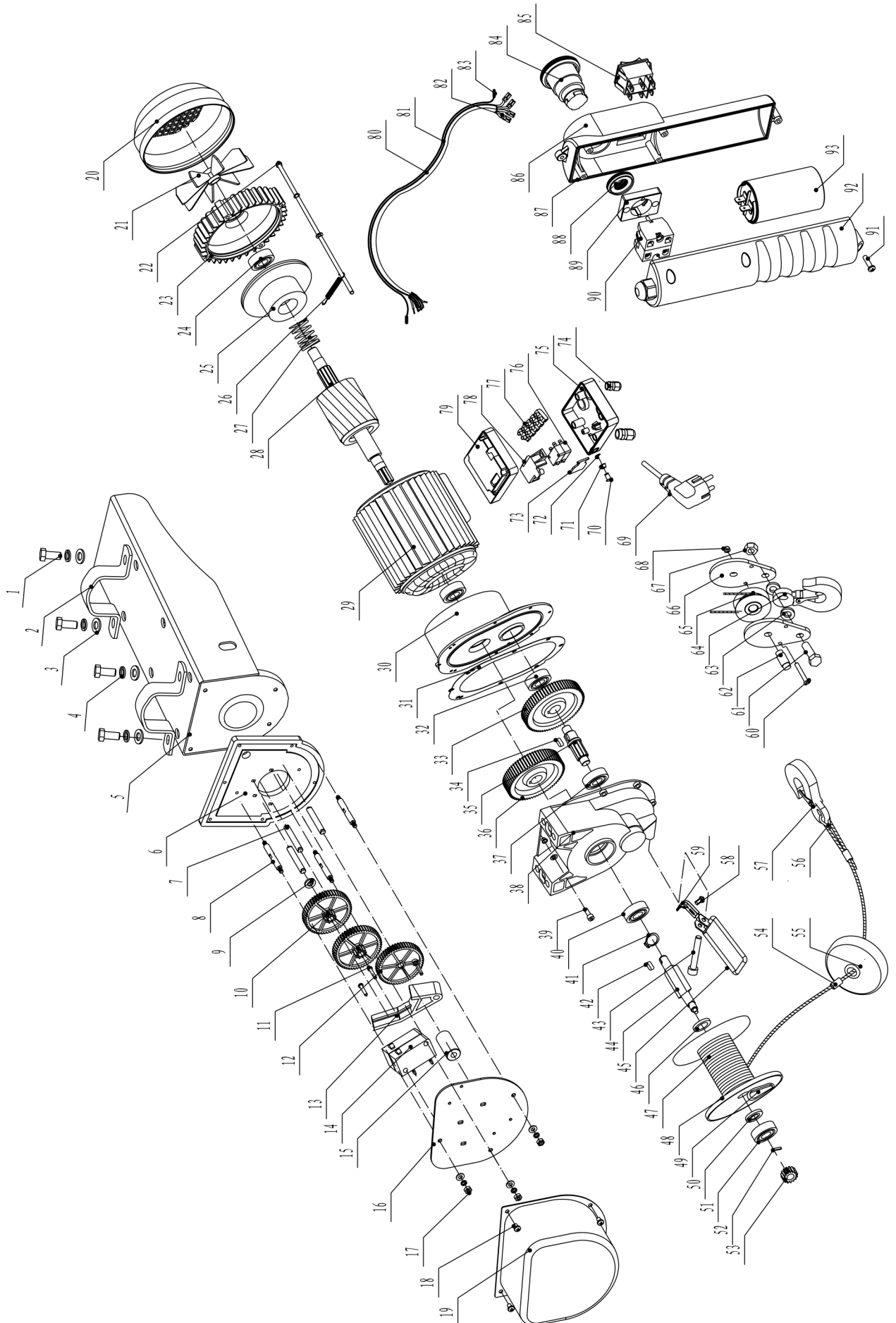

PARTS LIST & DIAGRAM

1	Hexagon bolt	32	Bearing	63	Hook washer
2	Fixing ring	33	First gear	64	Pulley hook
3	Flat washer	34	Flat key	65	Pulley
4	Spring washer	35	Gear shaft	66	Pulley splint
5	Support structure	36	Second gear	67	Prevailing torque type
6	Support board	37	Bearing	68	Prevailing torque type
7	Gear shaft	38	Gear case	69	Three-prong plug
8	Locating shaft	39	Socket head cap screw	70	Limit shaft
9	Flat washer	40	Bearing	71	U-waterproof cover
10	Silent gear	41	Elastic collar	72	Plastic closing ring
11	Crossed slot round bolt	42	Flat key	73	Switch connector
12	Driven gear	43	Socket head cap screw	74	Holding fixture
13	Turn plate	44	Rope shaft	75	Junction box cover
14	Jiggle switch	45	Limit frame	76	Limit switch
15	Axle sleeve	46	Rope inner washer	77	Terminal
16	Limited switch plate	47	Wire rope	78	Switch plate
17	Hexagon nut	48	Rope roll	79	Junction box base
18	Crossed slot round bolt	49	Wedge	80	Cable conductor
19	Protection cover	50	Rope external washer	81	Plastic coated wire ropes
20	Fan housing	51	Bearing	82	Socket
21	Fan blade	52	Straight pin	83	Lanyard plate
22	Hexagon bolt	53	Driving gear	84	Emergency stop switch
23	Aft closure	54	Aluminum pipe	85	Rise and down switch
24	Bearing	55	Block	86	Upper lid of the handle
25	Brake component	56	Rope thimble	87	Handle seal
26	Upper limit spring	57	Hook	88	Adjusting locknut
27	Tripping spring	58	Crossed slot round bolt	89	The switch block base
28	Rotor	59	Plastic limit piece	90	Urgent stop switch
29	Stator casing assembly	60	Hexagon bolt	91	Crossed slot round bolt
30	Front cover	61	Hexagon bolt	92	Lower lid of the handle
31	Sealed paper pad	62	Wheel axle	93	Capacitor

MAINTENANCE

The hoist should be thoroughly checked over at regular intervals to ensure that it is undamaged and that it is functioning correctly.

Isolate from the power supply and inspect the following for any signs of damage, wear or looseness, as appropriate:

- a) Lifting cable
- b) Electrical cables/connections
- c) Control switch
- d) Mounting brackets/bolts
- e) Support structure

Rectify any faults that are found, before using the hoist again. Reconnect to power supply and check for correct operation of the control switch and the maximum lift cut-out switch - the hoist should stop when the counterweight lifts the cut-out arm.

Contact Jefferson Tools for all information relating to the repair and maintenance of this equipment. Use only approved replacement parts. Damage caused by misuse of the hoist, poor maintenance or use of unauthorised parts will void the warranty offered with this product.

ENVIRONMENTAL PROTECTION



PLEASE RECYCLE

Recycle any packaging and unwanted materials instead of disposing of them as waste. All tools, accessories and packaging should be sorted, taken to a recycling centre and disposed of in a manner which is compatible with the environment.

When the product becomes completely unserviceable, reaches the end of its working life and requires disposal, drain off any fluids (if applicable) into approved containers and dispose of the product and the fluids according to local regulations.

WEEE Waste Electrical and Electronic Equipment Statement

Information on Disposal for Users of Waste Electrical & Electronic Equipment



This symbol on the product(s) and / or accompanying documents means that used electrical and electronic products should not be mixed with general household waste. For proper treatment, recovery and recycling, please take this product(s) to designated collection points where it will be accepted free of charge.

For private households:

Dispose of this product at the end of its working life and in compliance with the EU Directive on Waste Electrical and Electronic Equipment (WEEE). Contact your local solid waste authority for recycling information for this equipment. Disposing of this product correctly will help save valuable resources and prevent any potential negative effects on human health and the environment, which could otherwise arise from inappropriate waste handling. Please contact your local authority for further details of your nearest designated collection point. Penalties may be applicable for incorrect disposal of this waste, in accordance with your national legislation.

For business users in the European Union:

If you wish to discard electrical and electronic equipment, please contact your dealer or supplier for further information.

Information on Disposal in other Countries outside the European Union:

This symbol is only valid in the European Union. If you wish to discard this product please contact your local authorities or dealer and ask for the correct method of disposal.

RoHS (2014/35/EU - Restriction of Hazardous Substances)



Based on randomly-sampled examination of the evaluated product, the results of Lead, Cadmium, Hexavalent chromium, Polybrominated biphenyls (PBB), Polybrominated diphenyl ethers (PBDE) in tested samples comply with the limits as set by RoHS Directive 2011/65/EU ANNEX II; recasting 2002/95/EC.

WARRANTY

Jefferson Professional Tools & Equipment, warrants its customers that its products will be free of defects in workmanship or material. Jefferson shall, upon suitable notification, correct any defects, by repair or replacement, of any parts or components of this product that are determined by Jefferson to be faulty or defective.

This warranty is void if the equipment has been subjected to improper installation, storage, alteration, abnormal operations, improper care, service or repair. Unless otherwise stated, the guarantee is 12 months from purchase date, proof of which is required for any claim.

Full details of how you can register and activate your warranty as well as instructions on how to make a warranty claim are available on our website: <https://jeffersonstools.com/warranty-repairs>.

For any further information relating to Jefferson warranty cover please call +44 (0)1244 646 048 (UK) or +353 (0)1473 0300 (ROI).

EU DECLARATION OF CONFORMITY

We, Jefferson Professional Tools & Equipment, as the authorised UK representative of the manufacturer, declare that this equipment conforms to the requirements of the following:

EN ISO 12100:2010 - Safety of machinery — General principles for design — Risk assessment and risk reduction

EN 14492-2 - Cranes – Power driven winches and hoists Part 2: Power driven hoists

2014/30/EU EMC Directive

2006/42/EC Machinery Directive

2011/65/EU RoHS Directive

Notified Testing Body: TÜV Rheinland (China) Ltd.
Equipment Category: Electric Rope Hoist
Product Code / Description: JEFPOWH400 • 400kg Power Hoist (230V)

Signed By:



Name and address of manufacturer or authorised representative:

Jefferson Professional Tools & Equipment
24 Lisgorgan Lane, Upperlands, BT46 5TE,

Date:

22.02.2023

Tel: +44 (0)1244 646 048 (UK)
+353 (0)1473 0300 (ROI)
Email: info@jeffersontools.com

UKCA DECLARATION OF CONFORMITY

We, Jefferson Professional Tools & Equipment, as the authorised UK representative of the manufacturer, declare that this equipment conforms to the requirements of the following:

BS EN 55014-1:2017

BS EN 55014-2:1997+A2

BS EN 55014-2:2015

BS EN 61000-3-2:2014

BS EN IEC 61000-3-2:2019

BS EN 61000-3-3:2013

BS EN 61000-3-3:2013+AI

Notified Testing Body: TÜV Rheinland (China) Ltd.
Equipment Category: Electric Rope Hoist
Product Code / Description: JEFPOWH400 • 400kg Power Hoist (230V)

Signed By:

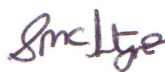

Name and address of manufacturer or authorised representative:

Jefferson Professional Tools & Equipment
24 Lisgorgan Lane, Upperlands, BT46 5TE,

Date:

22.02.2023

Tel: +44 (0)1244 646 048 (UK)
+353 (0)1473 0300 (ROI)
Email: info@jeffersontools.com



IMPORTANT! SAFETY FIRST!

Before attempting to use this product please read all the safety precautions and operating instructions outlined in this manual to reduce the risk of fire, electric shock or personal injury.

**UK
CA**

CE



Jefferson Professional Tools & Equipment
24 Lisgorgan Lane,
Upperlands,
BT46 5TE

Tel: +44 (0)1244 646 048 (UK) / +353 (0)1473 0300 (ROI)
Email: info@jeffersonstools.com

www.jeffersonstools.com