

# Jefferson®

PROFESSIONAL TOOLS & EQUIPMENT

**30"**  
760mm

**HIGH VELOCITY  
DRUM FAN**  
123W • 110V ~ 50Hz • 16A

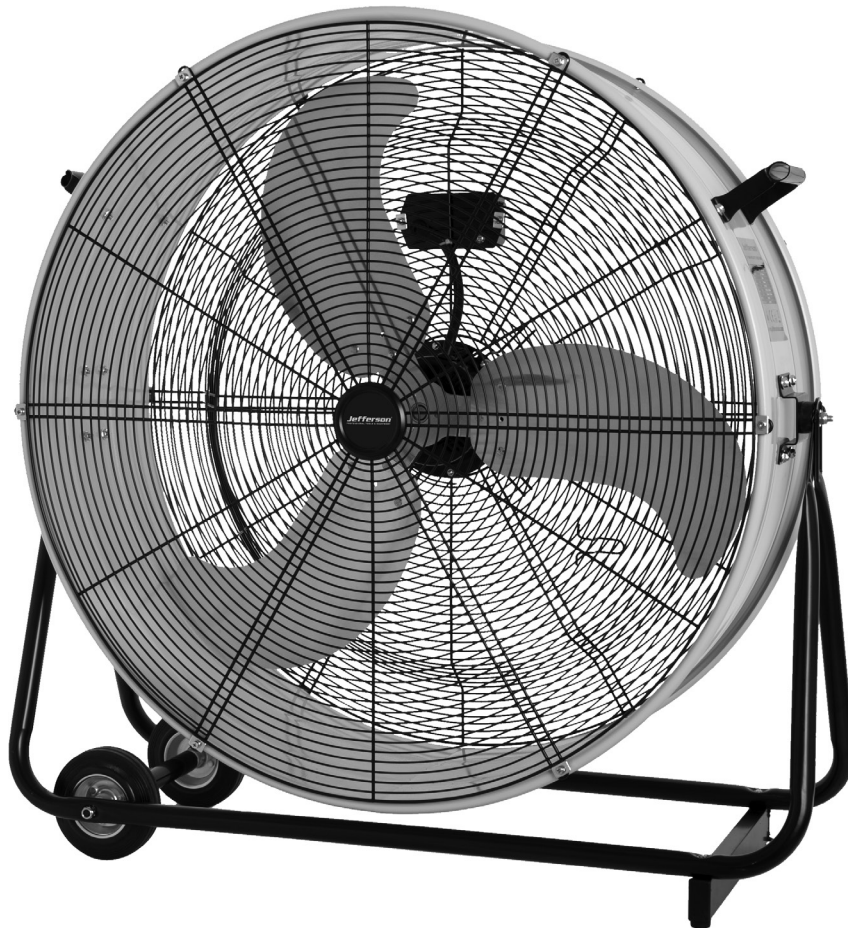

**JEFFANDRM30-110**

**User Manual**  
v.1.2





## INTRODUCTION

- A high-velocity two-speed drum fan capable of moving large volumes of air.
- Durable and robust design with heavy-duty gauge steel casing, guard, handle, wheels and frame.
- Cradle stand with tilt function allows flexible control of airflow when required.
- Balanced and fully guarded blades provide quiet and safe operation.
- Suitable for use in industrial, commercial, agricultural, automotive workshop and on-site applications.
- Energy efficiency tested according to EU 206/2012 regulations and standards (ERP 206 Compliant)

## SPECIFICATIONS

Model Number:		<b>JEFFANDRM30-110</b>
Voltage ~ Frequency:		110V ~ 50Hz (16A)
Fan Diameter:		30" • 760mm
Power:		123W
Speed:	High	1400rpm
	Low	1295rpm
Air Flow:	High	179.2cmm • 6328cfm
	Low	154cmm • 5720cfm
Net Weight:		20.4kg

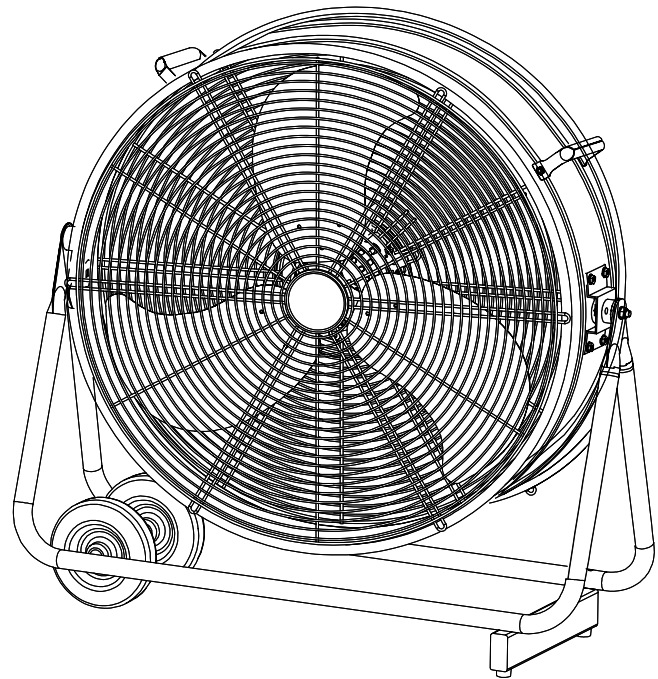

### Energy Efficiency (According To EU 206/2012 - ERP 206)

Item	Symbol	Unit	Value
Maximum Fan Flow Rate	F	m <sup>3</sup> /min	179.2
Fan Power Input	P	W	120.67
Service Value	SV	(m <sup>3</sup> /min)/W	1.49
Standby Power Consumption	PSB	W	0.00
Seasonal Electricity Consumption	Q	kWh/a	38.6
Fan Sound Power Level	LWA	dB(A)	84.5
Maximum Air Velocity	C	meters / sec	2.15

## UNPACKING & ASSEMBLY

Upon receipt of the equipment, ensure all components are present and have remained undamaged in transit. Retain the packing materials and packaging in case future transportation of the fan is necessary.

We recommend that the packaging is kept, at least within the period of the guarantee.

The diagram (**Fig.1**) and table shown below show the main components of the fan and how they are assembled for maintenance and servicing.

Part #	Part Description	Quantity
1	Front Guard	1
2	Fan Blade	1
3	Drum Body	1
4	Rear Guard	1
5	Motor	1
6	Switch Box	1
7	Switch	1
8	Power Cable / Plug	1
9	Frame	1
10	Wheels	2

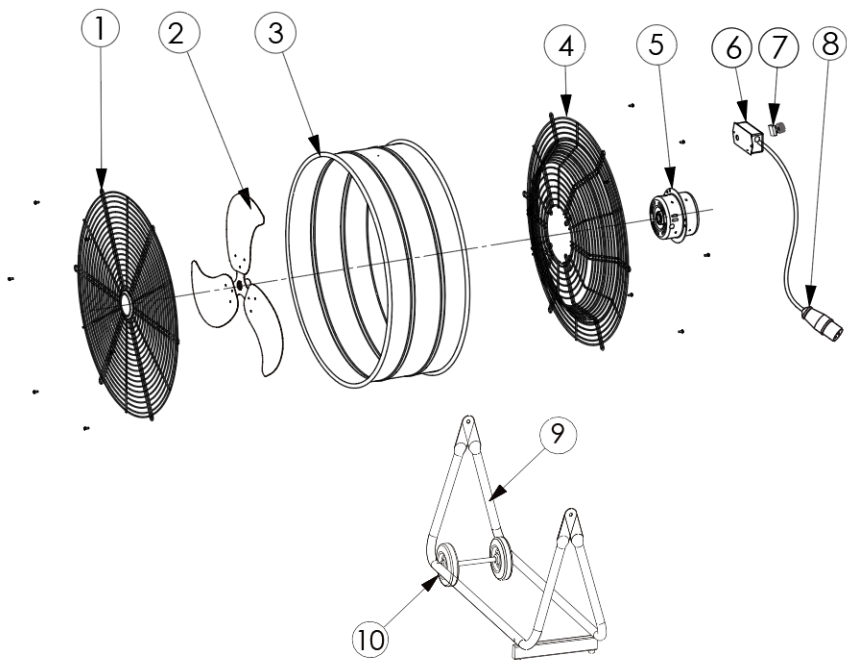

## SAFETY GUIDELINES



Please read and ensure that you understand all of the operating instructions, safety precautions and warnings in this Instruction Manual before operating or maintaining this equipment. An accident can often be avoided by recognizing a potentially hazardous situation before it occurs, and by observing appropriate safety procedures.

Hazards that must be avoided to prevent bodily injury or machine damage are identified by warnings on the equipment and in this Instruction Manual.

Never use this equipment or modify it in any way that has not been specifically recommended by the manufacturer. Contact Jefferson Tools for all information relating to the repair and maintenance of this equipment.

Contact a qualified electrician for advice on any issues relating to electrical safety in your working environment.

## SAFETY GUIDELINES

### ELECTRICAL SAFETY



Ensure that you check the equipment thoroughly to ensure it is safe and fit for purpose before each use. It is important that you inspect all plugs, sockets, power cables and electrical fittings for wear and damage and repair or replace any defective components. The risk of electric shock can be minimised by the correct use of the appropriate electrical safety devices.

- We recommend that you fit a **Residual Current Circuit Breaker (RCCB)** in the main distribution board and that a **Residual Current Device (RCD)** is used when operating this equipment.
- The **Electricity at Work Act 1989** includes legislation that places legal implications on employers to ensure the safety of electrical devices in the workplace. The regulations dictate that all portable equipment must be inspected regularly and tested to ensure that it is safe for use. 'Portable equipment' means any electrical item that can be moved and this is often referred to as **Portable Appliance Testing (PAT)**. PAT testing should be carried out regularly on this equipment by trained, authorised personnel, as required by the legislation.
- The **Health and Safety at Work Act 1974** states that it is the responsibility of the owner of electrical appliances to ensure that both the equipment and working environments are maintained to ensure safe operation at all times.
- Check that all equipment cables are secure, correctly insulated, free from damage, and protected against short circuit and overload before connecting to the power supply. Do not use worn or damaged cables, plugs, sockets or other fittings.
- Ensure that the power supply matches voltage requirements specified on the equipment and that the plug is wired correctly and fitted with a 16A fuse (See **Fig.2**).  
Ensure the power cable is kept away from heat, oil and sharp edges.
- Always disconnect the equipment from the power source before servicing, inspecting, maintaining, cleaning, replacing or checking any parts.
- Do not carry the equipment while it is connected to its power source.
- Do not use this equipment in damp or wet conditions or areas with high condensation such as showers, pools etc.

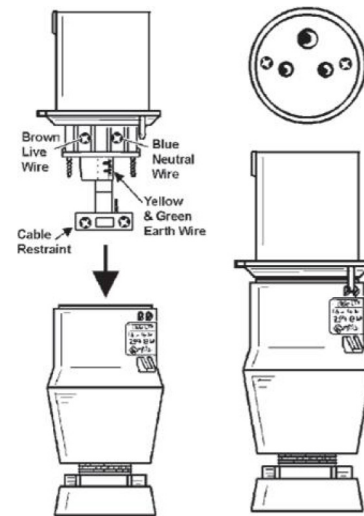

Fig.2

### GENERAL EQUIPMENT SAFETY

- Do not touch the fan until it has been disconnected from the mains power supply.
- Always disconnect the fan from the power supply when moving it from one location to another.
- Ensure fan is stood on a firm, level surface during operation.
- The air flow generated from this equipment is powerful. Before use ensure that there is nothing nearby that can be damaged or displaced by the stream of air. Be careful that there are no naked flames or embers that can be blown by the air flow, even remotely.
- Keep the fan clean and maintained in good condition. For motor service contact an authorised service agent.
- Use only Jefferson approved replacement parts when repairing this equipment. Unapproved parts may be dangerous, and will invalidate your warranty. Speak to your nearest Jefferson dealer for advice.
- Never operate the fan in environments containing explosive or flammable gases, fumes or other hazardous substances.
- Never allow the fan to be placed on top of the power cable.
- Do not insert any objects through the fan guard.
- Do not cover the fan when in use.
- Never immerse the fan in water or any other liquid.
- Never allow children to operate the fan - keep children and animals away from the equipment during operation.
- Never operate the fan in a position where it can be knocked over or off a surface, or where the lead may cause a person to trip.
- This equipment is not suitable for outdoor use.
- Do not modify the speed control or attempt to fit any additional external speed control devices to the fan.
- When not in use place the fan in its original box, or otherwise cover, to protect from dust and store in a safe, dry, childproof environment.
- Always keep the user manual with the equipment for future reference.

## OPERATION

Please ensure that you read, understand and apply safety instructions in before attempting to use this equipment.

Check that the speed control is set to "0" (OFF) and then plug into the mains power supply and switch the power on.

The fan is equipped with 2 speed settings ("1" = Low "2" = High) to control the rate of air flow delivered. Select the speed setting you require using the switch located at the back of the fan, above the motor.

Adjust the direction of the air flow by moving from side to side and tilting the fan up or down, as required.

When you have finished using the fan ensure you turn the speed control switch back to "0" (OFF) and disconnect the fan from the mains power.

## MAINTENANCE

### Equipment - General Cleaning:

- Use a soft, damp cloth to clean the fan after use .
- Never use solvents, petroleum, paint thinner or other chemicals to clean the fan.

### Cleaning The Fan Blade:

- Undo the cross headed screws around the circumference, remove the grille and clean the blade with a slightly damp cloth.
- Replace the grille as required and refit the cross headed screws.

### Servicing:

Should the motor, switch or the power lead require service or maintenance contact your local service agent.

### Storage:

When not in use place the fan in its original box or otherwise cover to protect from dust, and store in a safe, dry, environment and safe from children and animals.

**Jefferson**<sup>®</sup>  
PROFESSIONAL TOOLS & EQUIPMENT

### Parts & Servicing

For Jefferson approved replacement parts contact your nearest dealer or contact Jefferson tools

Telephone: +44 (0)1244 646 048

Fax: +44 (0)1244 241 191

Email: [warranty@jeffersonstools.com](mailto:warranty@jeffersonstools.com)

## ENVIRONMENTAL PROTECTION



Recycle any packaging and unwanted materials instead of disposing of them as waste. All tools, accessories and packaging should be sorted, taken to a recycling centre and disposed of in a manner which is compatible with the environment.

When the product becomes completely unserviceable, reaches the end of its working life and requires disposal, drain off any fluids (if applicable) into approved containers and dispose of the product and the fluids according to local regulations.

## WEEE Waste Electrical and Electronic Equipment Statement



### Information on Disposal for Users of Waste Electrical & Electronic Equipment

This symbol on the product(s) and / or accompanying documents means that used electrical and electronic products should not be mixed with general household waste. For proper treatment, recovery and recycling, please take this product(s) to designated collection points where it will be accepted free of charge.

### For private households:

**Dispose of this product at the end of its working life and in compliance with the EU Directive on Waste Electrical and Electronic Equipment (WEEE). Contact your local solid waste authority for recycling information for this equipment.**

Disposing of this product correctly will help save valuable resources and prevent any potential negative effects on human health and the environment, which could otherwise arise from inappropriate waste handling.

Please contact your local authority for further details of your nearest designated collection point.

Penalties may be applicable for incorrect disposal of this waste, in accordance with your national legislation.

### For business users in the European Union:

If you wish to discard electrical and electronic equipment, please contact your dealer or supplier for further information.

### Information on Disposal in other Countries outside the European Union:

This symbol is only valid in the European Union. If you wish to discard this product please contact your local authorities or dealer and ask for the correct method of disposal.

## RoHS Directive 2011/65/EU

We hereby declare that this equipment has been tested and found to be compliant to RoHS Directive 2011/65/EU of the European Parliament and the Council from 08/06/2011 on restriction of the use of certain hazardous substances in electrical and electronic appliances.

Determination of levels of regulated substances in electrotechnical products, elements of Cadmium (Cd), Lead (Pb), Mercury (Hg), Chromium (Cr) and Bromine (Br) contents were measured by XRF Spectroscopy and chemical confirmation test for RoHS restricted substances.



**EC DECLARATION OF CONFORMITY**

We, Jefferson Tools as the authorised European Community representative of the manufacturer, declare that the following equipment conforms to the requirements of the following directives, standards and regulations:

Directive / Standard:	Description:	Notified Body:
IEC 60335-2-80:2015	Household and similar electrical appliances - Safety - Part 2-80: Particular requirements for fans	Intertek Testing Services Shenzhen Ltd.
2011/65/EU (as amended)	RoHS Directive	
Regulation (EC) No 1907/2006	Registration, Evaluation, Authorisation and Restriction of Chemicals (REACH)	
EU 206/2012 (ERP 206)	Energy Related Products:  Test Standards:  IEC 60879:1986/COR1:1992 EN 50564:2011 EN 60704-1:2010+A11:2012 EN 60704-2-7:1998	

**Equipment Category:** Electric Fan

**Model Number • Description:** JEFFANDRM30-110 • 30" - HIGH VELOCITY DRUM FAN 110V - 50Hz - 123W

**Signed by:** Stephen McIntyre  

**Position in the company:** Operations Director  
**Date:** 07 January 2020

**Name and address of manufacturer or authorised representative:** Jefferson Tools, Herons Way, Chester Business Park, Chester, United Kingdom, CH4 9QR  
Telephone: +44 (0)1244 646 048  
Fax: +44 (0)1244 241 191  
Email: enquiries@jeffersonstools.com



## LIMITED WARRANTY STATEMENT

Jefferson Professional Tools & Equipment, or hereafter "Jefferson" warrants its customers that its products will be free of defects in workmanship or material. Jefferson shall, upon suitable notification, correct any defects, by repair or replacement, of any parts or components of this product that are determined by Jefferson to be faulty or defective.

This warranty is void if the equipment has been subjected to improper installation, storage, alteration, abnormal operations, improper care, service or repair.

### Warranty Period

Jefferson will assume both the parts and labour expense of correcting defects during the stated warranty periods below.

All warranty periods start from the date of purchase from an authorised Jefferson dealer. If proof of purchase is unavailable from the end user, then the date of purchase will be deemed to be 3 months after the initial sale to the distributor.

#### 1 Year:

JEFFANDRM30-110 • 30" HIGH VELOCITY DRUM FAN 110V - 50Hz - 123W

#### 90 Days

- All replacement parts purchased **outside** of the warranty period

**Important:** All parts used in the repair or replacement of warranty covered equipment will be subject to a minimum of 90 days cover or the remaining duration of the warranty period from the original date of purchase.

### Warranty Registration / Activation

You can register and activate your warranty by visiting the Jefferson Tools website using the following address:

[www.jeffersonstools.com/warranty](http://www.jeffersonstools.com/warranty) and completing the online form. Online warranty registration is recommended as it eliminates the need to provide proof of purchase should a warranty claim be necessary.

### Warranty Repair

Should Jefferson confirm the existence of any defect covered by this warranty the defect will be corrected by repair or replacement at an authorized Jefferson dealer or repair centre.

### Packaging & Freight Costs

The customer is responsible for the packaging of the equipment and making it ready for collection. Jefferson will arrange collection and transportation of any equipment returned under warranty. Upon inspection of the equipment, if no defect can be found or the equipment is not covered under the terms of the Jefferson warranty, the customer will be liable for any labour and return transportation costs incurred.

These costs will be agreed with the customer before the machine is returned.

*\* Jefferson reserve the right to void any warranty for damages identified as being caused through misuse*

### Warranty Limitations

Jefferson will not accept responsibility or liability for repairs made by unauthorised technicians or engineers. Jefferson's liability under this warranty will not exceed the cost of correcting the defect of the Jefferson products.

Jefferson will not be liable for incidental or consequential damages (such as loss of business or hire of substitute equipment etc.) caused by the defect or the time involved to correct the defect. This written warranty is the only express warranty provided by Jefferson with respect to its products.

Any warranties of merchantability are limited to the duration of this limited warranty for the equipment involved.

Jefferson is not responsible for cable wear due to flexing and abrasion. The end user is responsible for routine inspection of cables for possible wear and to correct any issues prior to cable failure.

## Claiming Warranty Coverage

The end user must contact Jefferson Professional Tools & Equipment (Tel: +44 (0) 1244 646 048) or their nearest authorised Jefferson dealer where final determination of the warranty coverage can be ascertained.

### Step 1 - Reporting the Defect

#### Online Method:

- Visit our website [www.jeffersonstools.com/warranty](http://www.jeffersonstools.com/warranty) and complete the Warranty Returns form. You can complete the form online and submit it to us directly or download the form to print out and return by post.

#### Telephone Method:

Contact your Jefferson dealer or sales representative with the following information:

- Model number
- Serial number (usually located on the specification plate)
- Date of purchase

A Warranty Returns form will be sent to you for completion and return by post or fax, together with details of your nearest authorised Jefferson repair centre. On receipt of this form Jefferson will arrange to collect the equipment from you at the earliest convenience.

### Step 2 - Returning the Equipment

It is the customer's responsibility to ensure that the equipment is appropriately and securely packaged for collection, **together with a copy of the original proof of purchase**. Please note that Jefferson cannot assume any responsibility for any damage incurred to equipment during transit. Any claims against a third party courier will be dealt with under the terms & conditions of their road haulage association directives.

**Please note: Jefferson will be unable to collect or process any warranty requests without a copy of the original proof of purchase.**

### Step 3 - Assessment and Repair

On receipt, the equipment will be assessed by an authorised Jefferson engineer and it will be determined if the equipment is defective and in need of repair and any repairs needed are covered by the warranty policy. In order to qualify for warranty cover all equipment presented must have been used, serviced and maintained as instructed in the user manual.

Where repair is not covered by the warranty a quotation for repair, labour costs and return delivery will be sent to the customer (normally within 7 working days).

Note: If the repair quotation is not accepted Jefferson Professional Tools & Equipment will invoice **1 hour labour time at £30 per hour plus return carriage costs (plus VAT)**.

In cases where no fault can be found with the equipment, or, if incorrect operation of the equipment is identified as the cause of the problem, a minimum of 1 hour labour at **£30 per hour plus carriage costs** will be required before the equipment will be despatched back to the customer.

Any equipment repaired or replaced under warranty will normally be ready for shipment back to the customer within 7 working days upon receipt of the equipment at an authorised Jefferson Repair centre (subject to part availability). Where parts are not immediately available Jefferson will contact you with a revised date for completion of the repair.

## General Warranty Enquiries

For any further information relating to Jefferson warranty cover please call **+44 (0) 1244 646 048** or send your enquiry via email to [warranty@jeffersonstools.com](mailto:warranty@jeffersonstools.com)

#### Disclaimer:

*The information in this document is to the best of our knowledge true and accurate, but all recommendations or suggestions are made without guarantee. Since the conditions of use are beyond their control, Jefferson Tools® disclaim any liability for loss or damage suffered from the use of this data or suggestions. Furthermore, no liability is accepted if use of any product in accordance with this data or suggestions infringes any patent. Jefferson Tools® reserve the right to change product specifications and warranty statements without further notification. All images are for illustration purposes only.*





## IMPORTANT! SAFETY FIRST!

Before attempting to use this product please read all the safety precautions and operating instructions outlined in this manual to reduce the risk of fire, electric shock or personal injury.



Jefferson Tools,  
Herons Way,  
Chester Business Park,  
Chester,  
United Kingdom,  
CH4 9QR

**Tel.** +44 (0)1244 646 048  
**Email:** sales@jeffersonstools.com