

Jefferson®

PROFESSIONAL TOOLS & EQUIPMENT

25L COMPRESSOR
2HP • 8 BAR • DIRECT DRIVE



JEFC025L08B
Series

User Manual
v.1.2



CONTENTS

Introduction	4
Specifications	4
Unpacking & Assembly	4
Before First Use	5
Equipment Identification	5
Safety Guidelines	6
Warning Labels	8
Operation Guide	9
Troubleshooting	10
Maintenance	11
Parts Diagram - Main Assembly	12
Parts List - Main Assembly	13
Parts Diagram - Pump	14
Parts List - Pump	15
Environmental Protection	16
WEEE Waste Electrical and Electronic Equipment Statement	16
RoHS Directive 2011/65/EU - Compliancy	16
EC Declaration of Conformity	17
Limited Warranty Statement	18

Important: Please read all these instructions before operating this product and save these instructions. This manual has been compiled by Jefferson Tools and is an integrated part of the product with which it's enclosed and should be kept with it for the future reference.

This manual describes the purpose for which the product has been designed and contains all the necessary information to ensure its correct and safe use. We recommend that this manual is read before any operation or, before performing any kind of adjustment to the product and prior to any maintenance tasks. By following all the general safety instructions contained in this manual you will help to ensure operator safety and extend the potential lifespan of the equipment.

All photographs and drawings in this manual are supplied by Jefferson Tools to help illustrate the operation of the product. Whilst every effort has been made to ensure accuracy of information contained in this manual our policy of continuous improvement determines the right to make modifications without prior warning.

Note: The information contained in this Instruction Manual is designed to assist you in the safe operation and maintenance of the compressor. Some illustrations in this Instruction Manual may show details or attachments that differ from those on your own compressor. Contact your nearest Jefferson Dealer if you are unsure about any information included in this manual or require any additional information about the safe use, operation maintenance, or repair of this equipment.

INTRODUCTION

- Aluminium head with cast-iron cylinders ensures durability & long-running operation
- Direct-drive assembly with pump head connected to heavy-duty induction motor for reliable and quiet operation
- Suitable for general-purpose workshop applications
- Welded tank fully-compliant with the latest European manufacturing & safety standards
- Fitted with an automatic pressure cut-out switch with twin gauges displaying tank and working pressures
- Equipped with transportation handle, front rubber mounted feet and rear wheels to assist manoeuvrability
- Powder-coated finish on the tank provides protection against corrosion

SPECIFICATIONS

	JEFC025L08B-230	JEFC025L08B-110
Tank Capacity:	25L	25L
Input Voltage ~ Frequency:	230V ~ 50Hz	110V ~ 50Hz
Motor Output:	2HP	2HP
Plug Type / Rated Supply:	UK 3-Pin / 13A	UK 3-Pin / 16A
Pump:	Single Cylinder • 2900rpm	Single Cylinder • 2900rpm
Air Displacement:	7cfm (191 l/min)	7cfm (191 l/min)
Free Air Delivery:	97 l/min (3.4cfm)	97 l/min (3.4cfm)
Maximum Pressure:	8bar (116psi)	8bar (116psi)
Wheel Diameter:	135mm	135mm
Lubrication:	Semi-Synthetic SAE30 (Optional 15W-40) • 220 cc	Semi-Synthetic SAE30 (Optional 15W-40) • 220 cc
Weight:	NW: 27.5kg / GW: 29kg	NW: 27.5kg / GW: 29kg
Equipment Dimensions:	570 x 290 x 600mm	570 x 290 x 600mm
Carton Dimensions:	654 x 288 x 663mm	654 x 288 x 663mm

UNPACKING & ASSEMBLY

Remove compressor from the carton:

Wear protective gloves and cut the outer strapping with side cutters.

Remove the staples with long nose pliers and open the top flaps. With assistance, carefully lift the compressor and place it on the work surface (See Fig.1).

Carefully inspect the equipment for any missing items or damage incurred during transit.

If anything is found to be missing or damaged contact your nearest Jefferson Dealer.

We recommend that you store the packaging for the duration of the warranty period. If necessary, it will be easier to return the compressor to the service centre.

Fit the wheels (See Fig.2) and front feet, remove the transport bung from the oil filler hole and replace with the dipstick / breather supplied. Fit the air filter and add oil to the pump, if necessary.

Confirm that the mains voltage corresponds with the voltage shown on the compressor's data / specification plate.

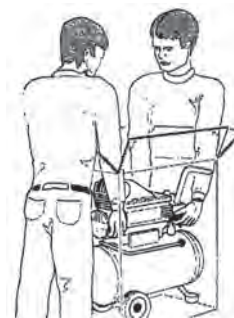

Fig.1

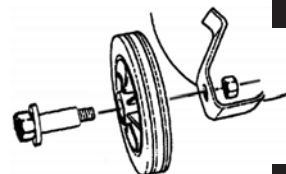

Fig.2

BEFORE FIRST USE

Check oil Level:

Before using the compressor check the oil level using the dipstick. If the oil is not up to the mark it should be topped up with **Jefferson HT68 Compressor oil** (see **Fig.3**).

Sight glass / Oil Level:

The compressor oil level can be viewed through the sight glass; the compressor must be on a level surface to measure the oil level through the sight glass accurately (see **Fig.4**):

- The top of the red dot indicates the full mark
- The bottom of the red dot indicates the low mark



Fig.3

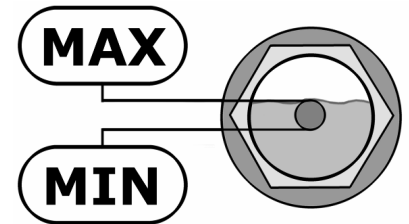

Fig.4

Important: Always ensure that the oil level is correct before operating the compressor.

Ensure working environment is suitable for use:

This compressor must be used on a flat, level surface. The maximum safe operating angle in any direction is 10° degrees (see **Fig.5**).

- Do not operate the compressor on inclines in excess of 10° degrees.
- Serious damage to pump components may result from insufficient lubrication.
- Never use the air compressor on a rooftop or elevated position that could allow the unit to fall or be tipped over.
- Use additional air hose for elevated jobs.

Check power supply is correct for this compressor:

It is essential that the air compressor has an adequate power supply. Always utilize more air hose before choosing to use an extension lead, as low voltage could cause damage to the motor. (Low voltage damage is not covered under warranty). Read and understand all the electrical safety guidelines laid out in this manual, follow all applicable local authority safety guidelines.

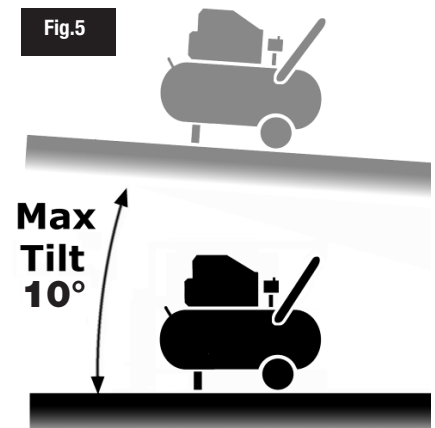
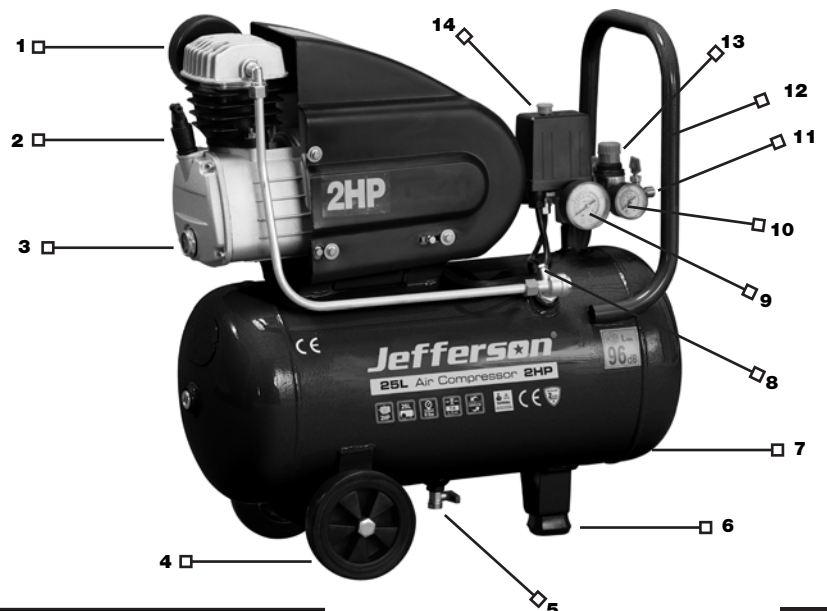

Fig.5

EQUIPMENT IDENTIFICATION

Number	Part Name
1	Air Filter
2	Oil Filler Cap / Breather / Dipstick
3	Oil Level Sight Glass
4	Wheel
5	Tank drain Valve
6	Rubber Feet
7	Pressure Tank
8	Check Valve
9	Tank Pressure Gauge
10	Working Pressure Gauge
11	Air Outlet
12	Handle
13	Regulator (Pressure Adjustment)
14	Pressure Switch (ON/OFF)



SAFETY GUIDELINES



Read and ensure that you understand all of the operating instructions, safety precautions and warnings in this Instruction Manual before operating or maintaining this compressor. Most accidents that result from compressor operation and maintenance are caused by the failure to observe basic safety rules or precautions. An accident can often be avoided by recognizing a potentially hazardous situation before it occurs, and by observing appropriate safety procedures. Hazards that must be avoided to prevent bodily injury or machine damage are identified by warnings on the compressor and in this Instruction Manual. Never use this compressor or modify it in any way that has not been specifically recommended by the manufacturer. Contact a qualified electrician for advice on any issues relating to electrical safety in your working environment.

ELECTRICAL SAFETY







Ensure that you check the equipment thoroughly to ensure it is safe and fit for purpose before each use. It is important that you inspect all plugs, sockets, power cables and electrical fittings for wear and damage and repair or replace any defective components. The risk of electric shock can be minimised by the correct use of the appropriate electrical safety devices.

- We recommend that you fit a **Residual Current Circuit Breaker (RCCB)** in the main distribution board and that a **Residual Current Device (RCD)** is used when operating this equipment.
- The **Electricity at Work Act 1989** includes legislation that places legal implications on employers to ensure the safety of electrical devices in the workplace. The regulations dictate that all portable equipment must be inspected regularly and tested to ensure that it is safe for use. 'Portable equipment' means any electrical item that can be moved and this is often referred to as **Portable Appliance Testing (PAT)**. PAT testing should be carried out regularly on this equipment by trained, authorised personnel, as required by the legislation.
- The **Health and Safety at Work Act 1974** states that it is the responsibility of the owner of electrical appliances to ensure that both the equipment and working environments are maintained to ensure safe operation at all times.
- Check that all equipment cables are secure, correctly insulated, free from damage, and protected against short circuit and overload before connecting to the power supply. Do not use worn or damaged cables, plugs, sockets or other fittings.
- Ensure that the power supply matches voltage requirements specified on the equipment and that the plug is wired correctly and fitted with the correct fuse.
- If the electrical fuse blows, ensure it is replaced by an identical type of fuse with the same rating.
- Never pull or manoeuvre this equipment into position using the power cable (move using the handle).
- Ensure the power cable is kept away from heat, oil and sharp edges.
- We recommend that the equipment is connected directly to the power supply without the use of extension leads as the resulting voltage drop can reduce motor and pump performance.
- Always disconnect the compressor from the power source and remove the compressed air from the air tank before servicing, inspecting, maintaining, cleaning, replacing or checking any parts.
- Do not carry the compressor while it is connected to its power source or when the air tank is filled with compressed air. Be sure the pressure switch is in the **"Off"** position before connecting the compressor to its power source.
- Do not use the compressor in damp / wet conditions.

EQUIPMENT SAFETY

- Never place your hands, fingers or other body parts near the compressor's moving parts during operation. Ensure that the equipment is isolated from the power supply and all switches in the **OFF** position before carrying out maintenance, repairs or adjustments.
- Never operate this compressor without all guards or safety features in place and in proper working order. If maintenance or servicing requires the removal of a guard or safety features, be sure to replace the guards or safety features before resuming operation of the compressor.
- Always wear safety goggles or equivalent eye protection. Compressed air must never be aimed at anyone or any part of the body.
- When not in use, the compressor should be stored in dry place. Keep out of reach of children. Keep children and animals away from the work area.
- Clear all work areas of unnecessary tools, debris, furniture etc. prior to use. Cluttered work areas can lead to injuries.
- Do not wear loose clothing or jewellery when operating this equipment. They can be caught in moving parts. Wear protective hair covering to contain long hair.
- Follow instructions for lubricating this equipment as required.
- Watch what you are doing and remove any potential distractions before use. Use common sense at all times.
- Do not operate this equipment when you are tired or if you are under the influence of alcohol, drugs or medication that makes you drowsy.
- Check for the correct alignment of moving parts, binding of moving parts, condition of parts, mounting, and air leaks, and any other issues that might affect the safe operation of this equipment. A guard or other part that is damaged should be properly repaired or replaced by an authorized Jefferson service centre unless otherwise indicated elsewhere in this instruction manual. Have defective pressure switches replaced by an authorized service centre. Do not use compressor if the switch does not turn it on and off.
- Operate the compressor according to the instructions provided in this manual. Never allow the compressor to be operated by children, individuals unfamiliar with its operation or unauthorized personnel.
- Keep all screws, bolts, and plates tightly mounted. Check regularly.
- The motor air vent must be kept clean so that air can freely flow at all times. Check for dust build-up frequently and clean as required.
- If the equipment appears to be operating unusually, making strange noises, or otherwise appears defective, stop using it immediately and arrange for repairs by a authorized service centre.
- Solvents such as petrol, thinner, benzine, carbon tetrachloride, and alcohol may damage and crack plastic parts. Do not wipe them with such solvents. Wipe plastic parts with a soft cloth lightly dampened with soapy water and dry thoroughly.
- Only use Jefferson approved replacement parts. Non-approved parts will void your warranty and can lead to malfunction and resulting injuries. Genuine parts are available from Jefferson your dealer.
- Do not modify the compressor for any use other than which it was designed for by the manufacturer. Do not tamper with or attempt to adjust the tank, pressure switch or safety valve. Never strap anything to the tank. Do not subject the tank to impact, vibration, heat, abrasion or corrosive materials.
- Always contact an authorized service centre for advice on any repairs. Unauthorized modification may not only impair the compressor performance but may also result in accident or injury to repair personnel who do not have the required knowledge and technical expertise to perform the repair operations correctly.
- When the compressor is not in use, ensure the pressure switch is turned off, disconnect the equipment from the power source and open the drain cock to discharge the compressed air from the air tank.
- To reduce the risk of burns, do not touch tubes, heads, cylinder and motors. During or immediately after use. Allow equipment to cool down before carrying out maintenance, repairs or adjustments.
- Never direct the output jet of air at persons or animals. Ensure air supply valve is turned **OFF** before disconnecting the air supply hose.
- Read the all safety instructions for any tool or accessory used with the compressor and ensure the safe working pressure of any appliance used exceeds the output pressure of the compressor. If you are using a spray gun it is important to ensure that the work area has sufficient ventilation in place.
- Do not operate in the vicinity of flammable liquids, gases or solids.
- Do not operate the compressor without an air filter or restrict the air flow around the equipment.
- When the compressor is not in use ensure that it is switched off, disconnected from the power supply and the air and moisture drained from the tank.

WARNING LABELS

Label	Potential Hazard	Prevention
 <p>WARNING RISK OF ELECTRICAL SHOCK</p>	<p>Water directed at electrical connections or switches, or objects connected to an electrical circuit, could result in a fatal electrical shock.</p> <p>Moisture or a liquid of any kind may conduct electricity and could result in a fatal electrical shock.</p> <p>Note: This equipment is not waterproof.</p>	<p>Never attempt to clean the air compressor while it is running. Direct any water or spray away from electric outlets and switches.</p> <p>Keep your air compressor out of the elements and well sheltered from rain, snow, dew, water or mist of any kind.</p> <p>Do not use the compressor with the supply cord damaged or with poor quality connections</p>
 <p>DANGER RISK OF EXPLOSION OR FIRE</p>	<p>Operating the air compressor in an explosive environment could result in a fire.</p> <p>Materials placed against or near the air compressor can interfere with its proper ventilation causing overheating and possible ignition of the materials.</p> <p>Improperly stored paint thinners could lead to accidental ignition.</p> <p>Good air flow is important as both the motor and compressor unit are air cooled. Restrictions to or insufficient air flow will cause overheating.</p>	<p>Never spray paint in a confined area with the air compressor.</p> <p>Operate the air compressor in well ventilated areas free from obstructions. Equip areas with fire extinguishers suitable for electrical fires. Do not leave nylon material shirts or jumpers on the compressor.</p> <p>Store paint thinners and other flammable liquids in approved containers, in a secure location away from the work area.</p> <p>Minimum clearance 0.5m / Maximum ambient operating temperature 45°C</p>
 <p>DANGER RISK TO BREATHING</p>	<p>This air compressor does not provide breathable air, the air may be contaminated with mineral based oils and other contaminants which poses the risk of serious lung infection and or injury.</p> <p>Spraying any material without the use of a face mask will result in the ingestion of foreign substances.</p>	<p>Never try to provide breathing air or refill auxiliary breathing apparatus using this compressor.</p> <p>Never spray substances in a closed location occupied by humans or animals always use a face mask when spraying substances</p>
 <p>WARNING RISK OF HOT SURFACES</p>	<p>Contact with hot surfaces, such as the cylinder head, cooling fins or discharge pipe, could result in serious burns.</p> <p>These parts will remain hot for some time after the compressor is shut down.</p>	<p>During operation, touch only the control surfaces of the air compressor. Keep children and animals far away from the air compressor at all times. They may not be able to recognize the hazards of this product.</p> <p>Allow the air compressor to cool before storage.</p>

Jefferson[®]
PROFESSIONAL TOOLS & EQUIPMENT

Parts & Servicing

For Jefferson approved replacement parts contact your nearest dealer or contact Jefferson tools

Telephone: +44 (0)1244 646 048

Fax: +44 (0)1244 241 191

Email: warranty@jeffersontools.com

OPERATION GUIDE

WARNING: Take care when selecting tools for use with the compressor. Air tool manufacturers normally express the volume of air required to operate a tool in cubic feet per minute (cfm). This refers to free air delivered by the compressor ('air out') which varies according to the pressure setting. Do not confuse this with the compressor displacement which is the air taken in by the compressor ('air in'). 'Air out' is always less than 'air in' due to losses within the compressor.

Starting The Compressor:

Before starting the compressor check that the Pressure / **ON/OFF** switch is in the "**OFF**" position, the regulator tap is closed, the output gauge must read Zero '0' bar.

Plug mains lead into mains supply and start the compressor by moving the main switch to the '**ON**' position.

The pressure switch automatically controls the power to the motor. It also allows for manual operation via the Push/Pull - On/Off switch on top of the pressure switch.

Use the Pressure Switch controls to turn the compressor "**ON/OFF**". The Pressure Switch is a push/pull switch type. To turn the compressor '**ON**' pull the switch knob upwards. To turn the compressor '**OFF**' push the knob downwards.

The pressure switch is factory set to turn the compressor on when the tank pressure drops below 85 psi and turn itself off again when the tank is full.

Note: When starting the compressor for the first time, leave it running with no air tools connected to the air outlet. Make sure that pressure in the tank rises and that the compressor stops automatically when the maximum pressure is reached - this information is indicated on the data specification plate and shown on the pressure gauge.

The compressor will now operate automatically. The pressure switch stops the motor when the maximum tank pressure is reached and restarts it when the pressure falls below the minimum threshold - approx. 2 bar (29psi) less than the maximum pressure.

Stopping The Compressor:

Stop the compressor by moving the main switch to the '**OFF**' position. The compressed air inside the compressor head will flow out, making the restart easier and preventing the motor from being damaged.

DO NOT, other than in an emergency, stop the compressor by switching off the mains socket, or by pulling the plug out, as the pressure relief will not then operate and motor damage may result upon restart.

When the compressor runs correctly and is stopped correctly there will be:

- (1) a whistle of compressed air when the motor stops,
- (2) a protracted whistle (about 20-25 seconds) when the compressor starts with no pressure in the tank.

Regulating The Pressure:

The output pressure is regulated by the pressure regulator. Lift and turn the knob clockwise to increase pressure and anticlockwise to reduce it - push knob down to lock in required position. To determine the correct working pressure for any piece of equipment check the corresponding manual for your tool.

When the compressor is not being used set the regulated pressure to zero so as to avoid damaging the pressure regulator.

WARNING: If the motor does not cut in and out, but runs continuously when using an air appliance, the capacity of the compressor may be too small for the equipment or tool.

The gauge indicates the pressure inside the main tank, NOT the pressure supplied to the air equipment. Should the pressure in the main tank exceed the pre-set switch maximum, a safety valve will activate.

For this reason DO NOT tamper with, or adjust, the switch or safety valve.

When the compressor is not in use, it should be switched off, disconnected from the mains supply and the air drained from the tank.

TROUBLESHOOTING

FAULT	CAUSE	REMEDY
Tank pressure drops continually.	Air leak, check all connections.	Locate and rectify leak. Run the compressor at maximum pressure then switch off and disconnect. Brush a soapy water solution over the connections and look for bubbles. Tighten any connections showing leaks. If problem persists contact your authorised service agent.
Tank pressure won't build up.	The drain valve is open.	Close the tank drain valve.
The compressor won't switch off. The safety valve blows off. Compressor does not stop when maximum pressure is reached.	Pressure switch fails to stop motor. Faulty pressure switch.	Contact your authorised service agent.
Tank pressure won't build up and the pump is getting hotter than normal, inlet suction is poor.	The compressor head gasket or valve plate is faulty. Fault with the air filter.	Contact your authorised service agent. Check, clean, replace air filter as required.
There is a leak from the base of the pressure switch when the compressor is running.	Failure of the pressure relief valve. (Located in the base of pressure switch).	Contact your authorised service agent.
There is a leak from the base of the pressure switch when the compressor is stopped.	The Non-return valve (from the tank) is leaking.	Disassemble and clean, if necessary replace valve insert. Contact your authorised service agent.
The compressor is noisy with metallic clangs / knocks.	Bearing or piston problem. Low oil level.	Stop the compressor and contact a specialized service technician.
The compressor sounds like it is trying to start (motor makes a humming noise).	Air pressure trapped on piston is resisting the starting effort. Faulty capacitor or fault within the electric motor.	Turn unit off and on again using the pressure switch. This will vent air from the delivery tube. Stop the compressor and contact a specialized service technician.
Overload switch activated.	Startup load may have activated overload switch. Extension lead is too long (if in use). Head unloader not functioning.	Leave for a few minutes then press the reset button and restart. Remove the extension lead and test compressor by connecting the compressor as close to the main fuse box as possible. Stop the compressor and contact a specialized service technician.
Air leaks from the safety valve at pressures less than 8 bar.	The safety valve is faulty.	Replace the safety valve.
Compressor stops and will not restart.	Power failure. Motor Failure.	Check electrical supply and fuse. Contact your authorised service agent.

MAINTENANCE

Before attempting any maintenance jobs on the compressor, make sure of the following:

1. The master power switch is turned off and equipment is isolated from the mains supply.
2. Pressure switch and the control unit switches are all in the **OFF** position.
3. All pressure has been removed from the air tank.

Procedure	Daily / Weekly	100Hrs	200Hrs	400Hrs
Check pump oil level	•			
Drain condensate water from the tank	•			
Check for unusual noise and vibration	•			
Inspect equipment for air leaks	•			
Check air filters		•		
Replace air filters			•	
General cleaning	•			
Check safety relief valve		•		
Check and tighten all bolts		•		
Check tubes fittings & electrical connections				•
Service pump / engine				•
Internal & external tank inspection				•
Replace the oil				•

Changing / Filling Compressor Pump Oil

- Ensure the compressor is turned off and disconnected from the power source.
- Allow the compressor pump and other parts to cool off (if changing oil after use).
- Ensure compressor is on a flat and level surface.
- Remove fill cap / plug and place collection container underneath the oil drain cap.
- Remove the oil drain cap, and let the oil drain out.
- Replace the oil cap and be sure to tighten this nut securely (you can use some PTFE tape on the thread to help create a tighter seal before tightening).
- Fill the oil reservoir with a compatible compressor oil (e.g **Jefferson HT68 Compressor Oil**).

Checking / Cleaning the Air Filter

- Ensure the compressor is turned off and disconnected from the power source.
- Allow the compressor pump and other parts to cool off (if changing filter after use).
- Unscrew the filter top from the filter base by turning (generally) counter-clockwise (the direction may vary depending on your filter).
- Separate the filter top cover from the base.
- Remove the filter element from the filter base.
- Blow out dust and debris from the filter element.
- Replace air filter element if required.
- Reconnect filter top to the base and secure filter.

PARTS DIAGRAM - MAIN ASSEMBLY

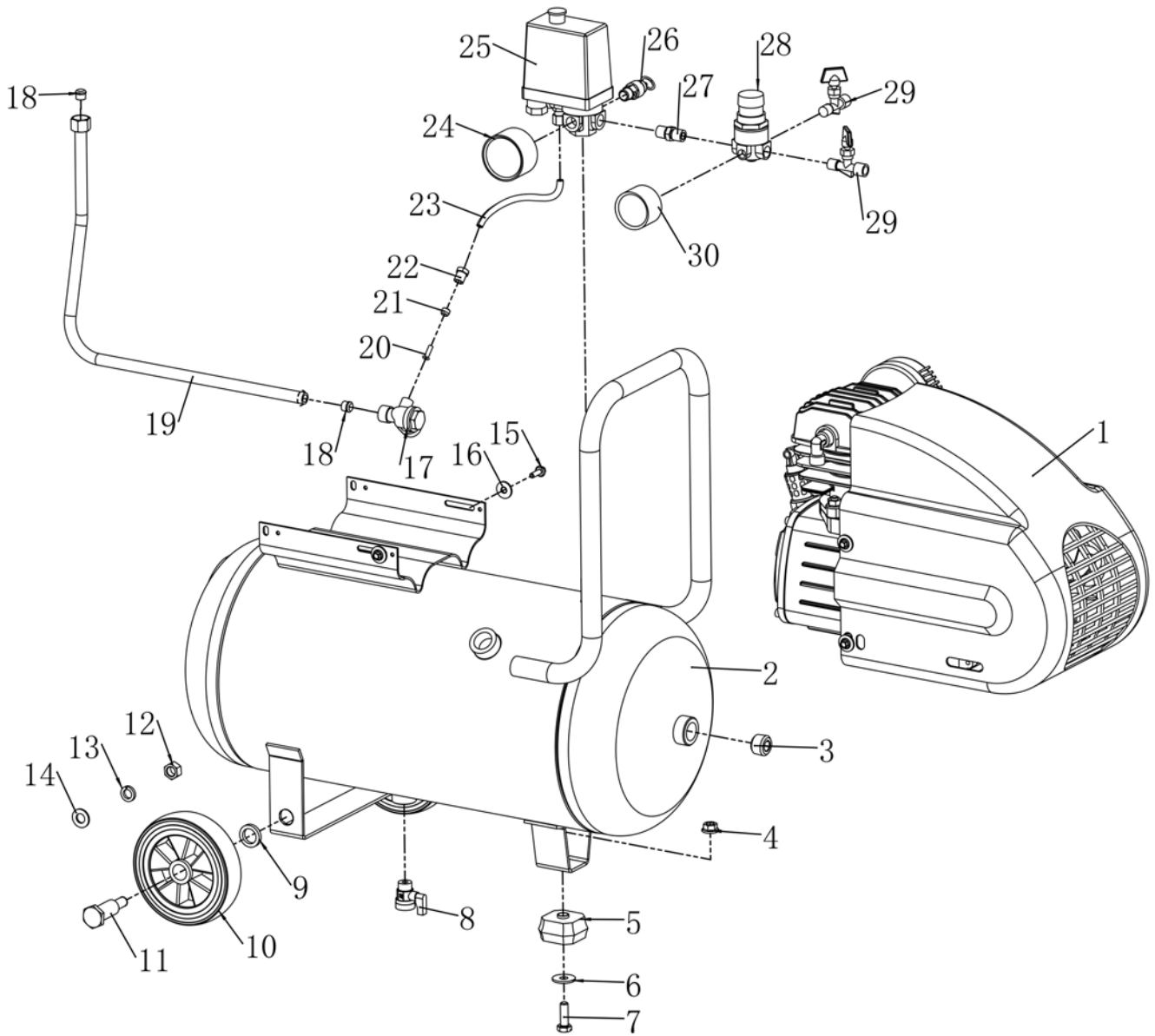

PARTS LIST - MAIN ASSEMBLY

#	Qty	Description
1	1	Pump
2	1	Air Tank
3	2	Plug
4	1	Hex Nut
5	1	Rubber Foot
6	1	Plate Washer
7	1	Hex Bolt
8	1	Ball Valve
9	2	Washer
10	2	Wheel
11	2	Axle
12	2	Hex Nut
13	2	Washer Spring
14	2	Plate Washer
15	6	Bolt Hex
16	4	Plate Washer
17	1	Check Valve
18	2	Sleeve
19	1	Aluminium Tube
20	1	Bushing - Nylon Tube
21	1	Sleeve
22	1	Sleeve Lock Nut
23	1	Nylon Tube
24	1	Pressure Gauge
25	1	Pressure Switch
26	1	Safety Valve
27	1	Nipple
28	1	Pressure Regulator
29	1	Ball Valve
30	1	Pressure Gauge

PARTS DIAGRAM - PUMP

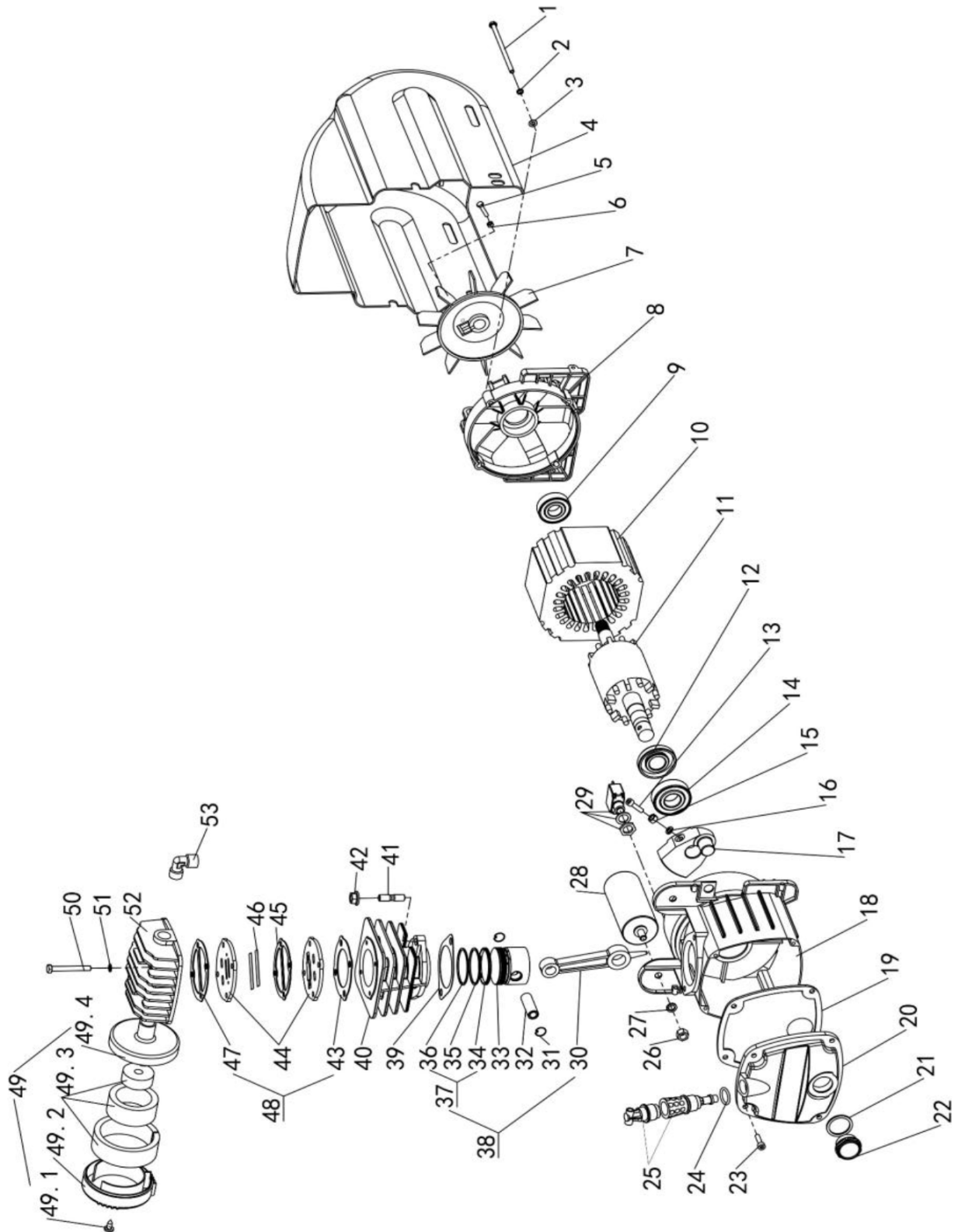

PARTS LIST - PUMP

#	Qty	Description	#	Qty	Description
1	4	Hex Screw	31	2	Circlip
2	4	Washer Spring	32	1	Piston Pin
3	4	Washer Plate	33	1	Piston
4	1	Shroud	34	1	Piston Ring Rod
5	1	Screw	35	1	Piston Ring
6	1	Hex Nut	36	1	Compression Ring
7	1	Fan	37	1	Piston Ring Kit
8	1	Rear Cover	38	1	Piston Kit
9	1	Bearing 6203	39	1	Gasket, Cylinder
10	1	Stator Ass'y	40	1	Cylinder
11	1	Rotor Ass'y	41	2	Stud Bolt
12	1	Oil Seal	42	2	Hex Nut
13	1	Head Bolt	43	1	Gasket, Valve
14	1	Bearing 6204	44	2	Valve, Plate
15	1	Hex Nut	45	1	Gasket, Valve
16	1	Washer Spring	46	2	Blade, Valve
17	1	Crankshaft	47	1	Gasket, Cylinder Head
18	1	Crankcase	48	1	Valve Kit
19	1	Gasket, Crankcase	49	1	Air Filter Ass'y
20	1	Front Cover	49.1	4	Air Filter Case UR
21	1	O-Ring	49.2	1	Element Kit
22	1	Oil Sight Glass	49.3	1	Air Filter Case LR
23	4	Head Bolt	49.4	1	Screw
24	1	O-Ring	50	4	Hex Screw
25	1	Air Breather	51	4	Washer Plate
26	1	Hex Nut	52	1	Cylinder Head
27	1	Washer Spring	53	1	Bend
28	1	Capacitor			
29	1	Overload Protector			
30	1	Conrod			

ENVIRONMENTAL PROTECTION



**PLEASE
RECYCLE**

Recycle any packaging and unwanted materials instead of disposing of them as waste. All tools, accessories and packaging should be sorted, taken to a recycling centre and disposed of in a manner which is compatible with the environment.

When the product becomes completely unserviceable, reaches the end of its working life and requires disposal, drain off any fluids (if applicable) into approved containers and dispose of the product and the fluids according to local regulations.

WEEE Waste Electrical and Electronic Equipment Statement



Information on Disposal for Users of Waste Electrical & Electronic Equipment

This symbol on the product(s) and / or accompanying documents means that used electrical and electronic products should not be mixed with general household waste. For proper treatment, recovery and recycling, please take this product(s) to designated collection points where it will be accepted free of charge.

For private households:

Dispose of this product at the end of its working life and in compliance with the EU Directive on Waste Electrical and Electronic Equipment (WEEE). Contact your local solid waste authority for recycling information for this equipment.

Disposing of this product correctly will help save valuable resources and prevent any potential negative effects on human health and the environment, which could otherwise arise from inappropriate waste handling.

Please contact your local authority for further details of your nearest designated collection point.

Penalties may be applicable for incorrect disposal of this waste, in accordance with your national legislation.

For business users in the European Union:

If you wish to discard electrical and electronic equipment, please contact your dealer or supplier for further information.

Information on Disposal in other Countries outside the European Union:

This symbol is only valid in the European Union. If you wish to discard this product please contact your local authorities or dealer and ask for the correct method of disposal.

RoHS Directive 2011/65/EU - COMPLIANCY

We hereby declare that this equipment has been tested and found to be compliant to RoHS Directive 2011/65/EU of the European Parliament and the Council from 08/06/2011 on restriction of the use of certain hazardous substances in electrical and electronic appliances.

Determination of levels of regulated substances in electrotechnical products, elements of Cadmium (Cd), Lead (Pb), Mercury (Hg), Chromium (Cr) and Bromine (Br) contents were measured by XRF Spectroscopy and chemical confirmation test for RoHS restricted substances.

RoHS requirement

Restricted substances	Limits
Cadmium (Cd)	0.01% (100 ppm)
Lead (Pb)	0.1% (1000 ppm)
Mercury (Hg)	0.1% (1000 ppm)
Chromium (VI) (Cr ^{VI})	0.1% (1000 ppm)
Polybrominated biphenyls (PBBs)	0.1% (1000 ppm)
Polybrominated diphenyl ethers (PBDEs)	0.1% (1000 ppm)

The above limits were quoted from RoHS Directive 2011/65/EU.

Date sample received: Apr 29, 2016

Testing period: Apr 29, 2016 to May 20, 2016; Jun 02, 2016 to Jun 12, 2016

EC DECLARATION OF CONFORMITY

We, Jefferson Professional Tools & Equipment, as the authorised European Community representative of the manufacturer, declare that the following equipment conforms to the requirements of the following Directives:

Directive:	Description:	Notified Body:
2000/14/EC (as amended)	Noise Emission in the Environment by Equipment for Use Outdoors	Ente Certificazione Macchine Srl Via Ca' Bella, 243 – Loc. Castello Di Serravalle – 40053 Valsamoggia (Bo) - Italy #1282
2014/30/EU (as amended)	Electromagnetic Compatibility	Sede Legale e Uffici Via Donatori di sangue, 9 - 46024 Moglia (MN) #0865
2006/42/EC (as amended)	Machinery Directive	
2014/35/EU (as amended)	Low Voltage Directive	
2014/29/EU (as amended)	Simple Pressure Vessels Directive	Technicka Inspekcia A.s. Trnavska Cesta 56 821 01 Bratislava Country : Slovakia #1354
2011/65/EU (as amended)	RoHS Directive	Intertek Testing Services, Shanghai Block B, Jinling Business Square, No.801 YiShan Road, Shanghai, China. 200233 #0012

Equipment Category: Air Compressor (Item 8)

Product Name/Model: **25L Compressor**
230V: JEFC025L08B-230
110V: JEFC025L08B-110

Measured Sound Power Level: 96dB

Guaranteed Sound Power Level: 96dB

Notified Body (Noise Emissions Testing): Technicka inspekcia a.s. Trnavska cesta 56
821 01 BRATISLAVA
Country : Slovakia

Phone : +421 2 49 208 100
Fax : +421 2 49 208 160

Notified Body Number: 1354

Signed by: Stephen McIntyre

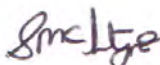

Position in the company: Operations Director

Date: 21 September 2018

Name and address of manufacturer or authorised representative: Jefferson Tools, Herons Way, Chester Business Park, Chester, United Kingdom, CH4 9QR
Telephone: +44 (0)1244 646 048 **Fax:** +44 (0)1244 241 191
Email: enquiries@jeffersonstools.com

LIMITED WARRANTY STATEMENT

Jefferson Professional Tools & Equipment, or hereafter "Jefferson" warrants its customers that its products will be free of defects in workmanship or material. Jefferson shall, upon suitable notification, correct any defects, by repair or replacement, of any parts or components of this product that are determined by Jefferson to be faulty or defective.

This warranty is void if the equipment has been subjected to improper installation, storage, alteration, abnormal operations, improper care, service or repair.

Warranty Period

Jefferson will assume both the parts and labour expense of correcting defects during the stated warranty periods below.

All warranty periods start from the date of purchase from an authorised Jefferson dealer. If proof of purchase is unavailable from the end user, then the date of purchase will be deemed to be 3 months after the initial sale to the distributor.

2 Years

- JEFC025L08B-230 • JEFC025L08B-110 - 25L 2HP 8Bar Direct Drive Air Compressor

90 Days

- All replacement parts purchased **outside** of the warranty period

Important: All parts used in the repair or replacement of warranty covered equipment will be subject to a minimum of 90 days cover or the remaining duration of the warranty period from the original date of purchase.

Warranty Registration / Activation

You can register and activate your warranty by visiting the Jefferson Tools website using the following address:

www.jeffersontools.com/warranty and completing the online form. Online warranty registration is recommended as it eliminates the need to provide proof of purchase should a warranty claim be necessary.

Warranty Repair

Should Jefferson confirm the existence of any defect covered by this warranty the defect will be corrected by repair or replacement at an authorized Jefferson dealer or repair centre.

Packaging & Freight Costs

The customer is responsible for the packaging of the equipment and making it ready for collection. Jefferson will arrange collection and transportation of any equipment returned under warranty. Upon inspection of the equipment, if no defect can be found or the equipment is not covered under the terms of the Jefferson warranty, the customer will be liable for any labour and return transportation costs incurred.

These costs will be agreed with the customer before the machine is returned.

* Jefferson reserve the right to void any warranty for damages identified as being caused through misuse

Warranty Limitations

Jefferson will not accept responsibility or liability for repairs made by unauthorised technicians or engineers. Jefferson's liability under this warranty will not exceed the cost of correcting the defect of the Jefferson products.

Jefferson will not be liable for incidental or consequential damages (such as loss of business or hire of substitute equipment etc.) caused by the defect or the time involved to correct the defect. This written warranty is the only express warranty provided by Jefferson with respect to its products.

Any warranties of merchantability are limited to the duration of this limited warranty for the equipment involved.

Jefferson is not responsible for cable wear due to flexing and abrasion. The end user is responsible for routine inspection of cables for possible wear and to correct any issues prior to cable failure.

Claiming Warranty Coverage

The end user must contact Jefferson Professional Tools & Equipment (Tel: +44 (0) 1244 646 048) or their nearest authorised Jefferson dealer where final determination of the warranty coverage can be ascertained.

Step 1 - Reporting the Defect

Online Method:

- Visit our website www.jeffersontools.com/warranty and complete the Warranty Returns form. You can complete the form online and submit it to us directly or download the form to print out and return by post.

Telephone Method:

Contact your Jefferson dealer or sales representative with the following information:

- Model number
- Serial number (usually located on the specification plate)
- Date of purchase

A Warranty Returns form will be sent to you for completion and return by post or fax, together with details of your nearest authorised Jefferson repair centre. On receipt of this form Jefferson will arrange to collect the equipment from you at the earliest convenience.

Step 2 - Returning the Equipment

It is the customer's responsibility to ensure that the equipment is appropriately and securely packaged for collection, **together with a copy of the original proof of purchase**. Please note that Jefferson cannot assume any responsibility for any damage incurred to equipment during transit. Any claims against a third party courier will be dealt with under the terms & conditions of their road haulage association directives.

Please note: Jefferson will be unable to collect or process any warranty requests without a copy of the original proof of purchase.

Step 3 - Assessment and Repair

On receipt, the equipment will be assessed by an authorised Jefferson engineer and it will be determined if the equipment is defective and in need of repair and any repairs needed are covered by the warranty policy. In order to qualify for warranty cover all equipment presented must have been used, serviced and maintained as instructed in the user manual.

Where repair is not covered by the warranty a quotation for repair, labour costs and return delivery will be sent to the customer (normally within 7 working days).

Note: If the repair quotation is not accepted Jefferson Professional Tools & Equipment will invoice **1 hour labour time at £30 per hour plus return carriage costs (plus VAT)**.

In cases where no fault can be found with the equipment, or, if incorrect operation of the equipment is identified as the cause of the problem, a minimum of 1 hour labour at **£30 per hour plus carriage costs** will be required before the equipment will be despatched back to the customer.

Any equipment repaired or replaced under warranty will normally be ready for shipment back to the customer within 7 working days upon receipt of the equipment at an authorised Jefferson Repair centre (subject to part availability). Where parts are not immediately available Jefferson will contact you with a revised date for completion of the repair.

General Warranty Enquiries

For any further information relating to Jefferson warranty cover please call **+44 (0) 1244 646 048** or send your enquiry via email to **warranty@jeffersontools.com**

Disclaimer:

The information in this document is to the best of our knowledge true and accurate, but all recommendations or suggestions are made without guarantee. Since the conditions of use are beyond their control, Jefferson Tools® disclaim any liability for loss or damage suffered from the use of this data or suggestions. Furthermore, no liability is accepted if use of any product in accordance with this data or suggestions infringes any patent. Jefferson Tools® reserve the right to change product specifications and warranty statements without further notification. All images are for illustration purposes only.



IMPORTANT! SAFETY FIRST!

Before attempting to use this product please read all the safety precautions and operating instructions outlined in this manual to reduce the risk of fire, electric shock or personal injury.



Jefferson Tools,
Herons Way,
Chester Business Park,
Chester,
United Kingdom,
CH4 9QR

Tel. +44 (0)1244 646 048
Email: sales@jeffersonsontools.com