

BELT LINISHER

JEFBLTSND075-230, JEFBLTSND075-400, JEFBLTSND150-230, JEFBLTSND150-400



WARNING!

Read carefully and understand all ASSEMBLY AND OPERATION INSTRUCTIONS before operating.
Failure to follow the safety rules and other basic safety precautions may result in serious personal injury



CONTENTS

Contents	3
About This Document	3
Specifications	4
Equipment Identification	4
Safety Guidelines	5
Transportation & Storage	7
Test Run	7
Adjusting The Sanding Angle	8
Sanding Tips	8
Belt Tracking Adjustment	8
Maintenance	9
Troubleshooting	10
Circuit / Wiring Diagram	11
Parts List - JEFBLTSND075-230 JEFBLTSND075-400	12
Parts Diagram - JEFBLTSND075-230 JEFBLTSND075-400	13
Parts List - JEFBLTSND150-230 JEFBLTSND150-400	14
Parts Diagram - JEFBLTSND150-230 JEFBLTSND150-400	15
Environmental Protection	16
WEEE Waste Electrical and Electronic Equipment Statement	16
RoHS Directive 2011/65/EU	16
EC Declaration Of Conformity	17
Limited Warranty Statement	18

ABOUT THIS DOCUMENT

This manual has been compiled by Jefferson Tools and is an integrated part of the product with which it's enclosed and should be kept with it for future reference. Please read all of the information supplied in this User Manual before operating this product.

This manual describes the purpose for which the product has been designed and contains all the necessary information to ensure its correct and safe use. We recommend that you read the information supplied before carrying out any maintenance or repair. By following all the general safety instructions contained in this manual you will help to ensure operator safety and extend the potential life span of the equipment.

All photographs and drawings in this manual are supplied by Jefferson Tools to help illustrate the operation of the product. Whilst every effort has been made to ensure accuracy of information contained in this manual our policy of continuous improvement determines the right to make modifications without prior warning.

The information contained in this Instruction Manual is designed to assist you in the safe operation and maintenance of the equipment. Some illustrations in this Instruction Manual may show details or attachments that differ from those on your own model. Contact your nearest Jefferson Dealer if you are unsure about any information included in this manual or require any additional information about the safe use, operation maintenance, or repair of this equipment.



SPECIFICATIONS

Model Number	JEFBLTSND075-230	JEFBLTSND075-400	JEFBLTSND150-230	JEFBLTSND150-400
Belt Size	75 x 2000mm	75 x 2000mm	150 x 2000mm	150 x 2000mm
Motor Power / Speed	2200W / 2800rpm	2600w / 2800rpm	2800W / 2800rpm	2400W @ 1400rpm 2800W @ 2800rpm
Input Supply	230V ~ 50Hz (1)	400V ~ 50 Hz (1)	230V ~ 50Hz (1)	400V ~ 50Hz (3)
Belt Speed	30m/s	30m/s	30m/s	30m/s
Table Size	75 x 460mm	75 x 460mm	150 x 460mm	150 x 460mm
Sound Power	LWA = 94.5 dB(A) LWA = 103 dB(A) on load	LWA = 94.5 dB(A) LWA = 103 dB(A) on load	LWA = 94.5 dB(A) LWA = 103 dB(A) on load	LWA = 94.5 dB(A) LWA = 103 dB(A) on load
Weight	63kg	63kg	81kg	81kg

* Sound Power Level:

The figures quoted in this table are emission (sound power) levels and are not necessarily safe working levels. Whilst there is a correlation between the emission and exposure levels, this can not be used reliably to determine whether or not further precautions are required. Factors that influence the actual level of exposure to the work-force include the characteristics of the work room, the other sources of noise, the number of machines and other adjacent processes, and the length of time for which an operator is exposed to the noise. Also the permissible exposure level can vary between regions. This information, however, will allow the user of the machine to make a better evaluation of the hazard and risk.

EQUIPMENT IDENTIFICATION

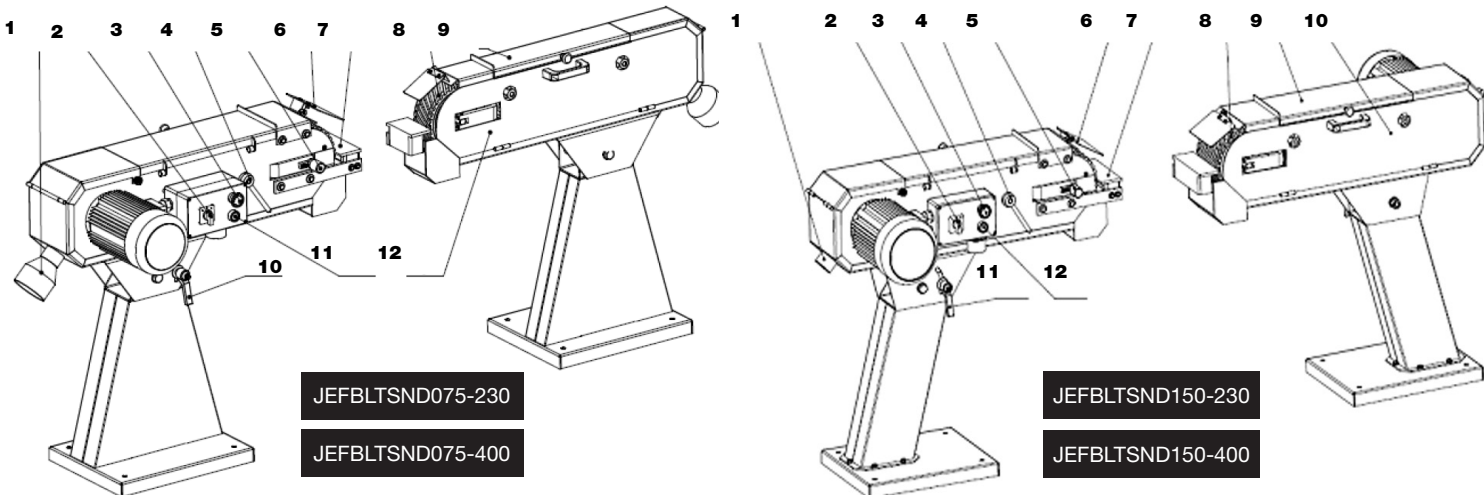

1. Dust Extraction Port
2. Mode Selection Switch
3. Stop Switch
4. Belt Tension Lever
5. Belt Tracking Adjustment Knob
6. Eye Shield
7. Spark Trap
8. Contact Wheel
9. Belt Guards
10. Angle Adjustment Lever
11. Start Switch
12. Cover Door

1. Dust Extraction Port
2. Mode Selection Switch
3. Stop Switch
4. Belt Tension Lever
5. Belt Tracking Adjustment Knob
6. Eye Shield
7. Spark Trap
8. Contact Wheel
9. Belt Guards
10. Cover Door
11. Angle Adjustment Lever
12. Start Switch

SAFETY GUIDELINES



Please read and ensure that you understand all of the operating instructions, safety precautions and warnings in this Instruction Manual before operating or maintaining this equipment. An accident can often be avoided by recognizing a potentially hazardous situation before it occurs, and by observing the appropriate safety procedures. Never use this equipment or modify it in any way that has not been specifically recommended by the manufacturer. Contact a qualified electrician for advice on any issues relating to electrical safety in your working environment.

GENERAL EQUIPMENT SAFETY

This machine is equipped with various safety devices protecting both the operator and the machine. These features cannot cover all aspects relating to safety, therefore the user should read all of the following safety guidelines carefully before operating this machine. Other safety concerns relating to the surrounding conditions and material should also be carefully considered before beginning to operate this machine.

- Before connecting the machine to the main power supply, ensure that all safety items are in their active positions and fully functional. Before removing the doors or protective safety covers, turn off the switch and disconnect the plug from its socket.
- Ensure that the kick-back catchers are moving freely and regularly check they are functioning as required throughout the day.
- Do not connect the machine to the mains while the door or protective cover is removed.
- Before operating the machine familiarise yourself with the location of all of the switches, paying particular attention to the location of the emergency stop switch so that you can use it promptly at any time.
- Do not touch any switches while the machine is being operated.
- Do not under any circumstances touch any rotating tool by hands or with any other objects.
- When not in use, turn off the machine using the off switch and disconnect the plug from the mains power supply.
- Before cleaning the machine, switch off the machine and disconnect the plug from the mains power supply.
- Before carrying out any maintenance work on the machine, switch off the machine and disconnect the plug from the mains power supply.
- Should a failure in power supply occur, switch off the machine immediately.
- Do not alter the machine in any manner which might cause any risk to its safe operation.
- Do not paint, cause any damage to, alter or remove safety plates. If they become illegible or is damaged, please contact the manufacturing plant and renew the plates.
- Keep work area clear around the machine. Cluttered areas can cause accidents and injuries.
- Remove personal articles, e.g. rings, watches, bracelets, neckties etc before working on the machine. Never wear any loose working clothes, button sleeves of shirts remove any neck ties, which may be caught with various parts of the working machine. Wear hair protection and fasten hair properly to avoid catching by moving part.
- Always wear the appropriate protective clothing including safety glasses, face shield, dust mask, earplugs, safety boots and leather apron, as required.
- Always wear a protective mask while machining any material that produces dust while being machined.
- Do not work on the machine under the influence of drugs or alcohol, or if you are tired.

5



WARNING:

No responsibility is accepted for incorrect use of this equipment. Incorrect use can result in damage to the equipment and danger to the user. Warranty will be void in the event of incorrect use. The warnings, cautions and instructions discussed in this instruction manual cannot cover all possible conditions and situations that may occur. It must be understood by the operator that common sense and caution are factors which cannot be built into this product, but must be supplied by the operator.

ELECTRICAL SAFETY



Ensure that you check the equipment thoroughly to ensure it is safe and fit for purpose before each use. It is important that you inspect all plugs, sockets, power cables and electrical fittings for wear and damage and repair or replace any defective components. The risk of electric shock can be minimised by the correct use of the appropriate electrical safety devices.

- We recommend that you fit a Residual Current Circuit Breaker (RCCB) in the main distribution board and that a Residual Current Device (RCD) is used when operating this equipment.
- The Electricity at Work Act 1989 includes legislation that places legal implications on employers to ensure the safety of electrical devices in the workplace. The regulations dictate that all portable equipment must be inspected regularly and tested to ensure that it is safe for use. 'Portable equipment' means any electrical item that can be moved and this is often referred to as Portable Appliance Testing (PAT). PAT testing should be carried out regularly on this equipment by trained, authorised personnel, as required by the legislation.
- The Health and Safety at Work Act 1974 states that it is the responsibility of the owner of electrical appliances to ensure that both the equipment and working environments are maintained to ensure safe operation at all times.
- Check that all equipment cables are secure, correctly insulated, free from damage, and protected against short circuit and overload before connecting to the power supply. Do not use worn or damaged cables, plugs, sockets or other fittings.
- Ensure that the power supply matches voltage requirements specified on the equipment and that the plug is wired correctly and fitted with the correct fuse.
- If the electrical fuse blows, ensure it is replaced by an identical type of fuse with the same rating.
- Never pull or manoeuvre this equipment into position using the power cable.
- Ensure the power cable is kept away from heat, oil and sharp edges.
- We recommend that the equipment is connected directly to the power supply without the use of extension leads as the resulting voltage drop can reduce motor performance.
- Always disconnect the equipment from the power source before servicing, inspecting, maintaining, cleaning, replacing or checking any parts.

WORK AREA SAFETY

- Always ensure a sufficient working area, that is clean and tidy, and free access to the machine and peripheral devices.
- Ensure sufficient lighting is available in the working area which will not create shadows or cause a stroboscopic effect.

SAFETY REGULATIONS FOR OPERATORS

Do not operate the machine without reading and understanding the contents of this user manual.

- Regularly inspect safety covers ensuring that they are mounted properly and undamaged. Repair damaged covers immediately or have them replaced with Jefferson Tools approved replacement parts.
- Do not operate the machine with the safety cover removed.
- Always use the machine for its intended purpose, do not modify the equipment for other uses.
- Never use the machine at speeds higher than the manufacturers' recommended speed settings.
- This equipment should only be repaired by fully-trained or approved engineers.
- Stop the machine and unplug from the mains power supply before replacing the finishing belt.
- Do not remove or interfere with safety devices such as safety covers and limit switches.
- It is not recommended to work on the machine during a storm.

TRANSPORTATION AND STORAGE

Ensure that responsible qualified personnel are used when transporting or moving the machine.

- While loading or unloading the machine, ensuring the area is clear of obstacles and people.
- Do not stand underneath the machine when being lifted by a crane or high-lift trolley!
- Ensure the machine is protected against excessive vibrations and humidity when transporting.
- The machine should be stored in a shelter location at temperatures between -25°C to 55°C.
- As standard, the machine is wrapped up in a plastic tray but may also be packed in a robust wooden box upon request.

WORKING CLEARANCES

Consider existing and anticipated needs, size of material to be processed through each machine, and space for auxiliary stands, work tables or other machinery when establishing a location for your new machine.

TEST RUN

Once the assembly is complete, test the machine to ensure it operation and performing as required.

If any unusual noise or vibration is detected during operation, stop using the machine immediately, turn the machine off and remove the mains power supply.

Unusual noises should always be investigated correctly before operating the machine further. Remember to disconnect the machine from the mains power supply when investigating or correcting potential problems.

To test run the machine:

1. Connect the machine to the mains power source.
2. Make sure the machine is set up correctly and read the safety instructions before proceeding any further.
3. Make sure all tools and objects used during set up are cleared away from the machine.
4. Turn the machine **ON** using the **START** switch.
5. Listen to and watch for abnormal noises or actions. The machine should run smoothly with little or no vibration or rubbing noises.

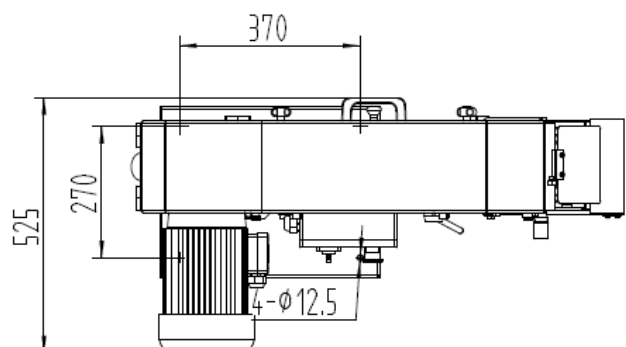
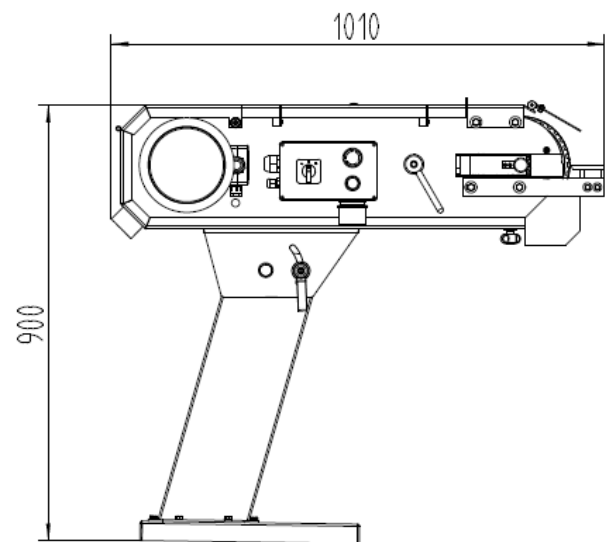

ADJUSTING THE SANDING ANGLE

The sander can be angled up and down to suit the users requirements.

Use the angle adjustment lever located on the side of the machine, to lock the sander in the angle you have chosen.

Tighten securely to ensure the sander will not move during operation.

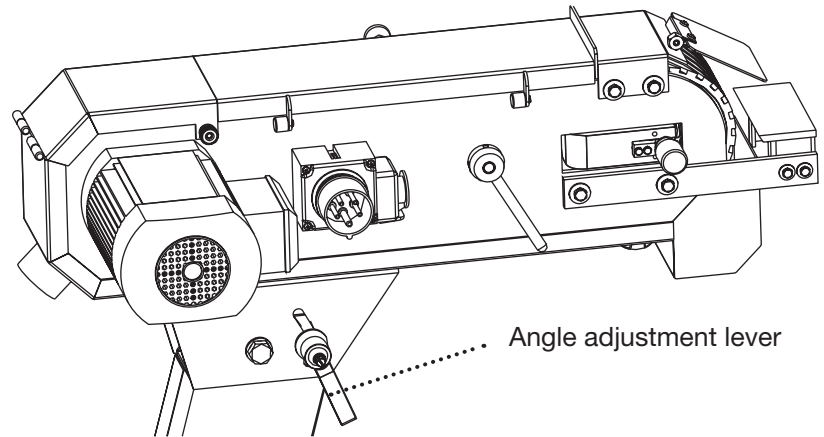

SANDING TIPS

- Ensure the belt guard is closed when grinding against the contact wheel.
- Hold the work piece securely with both hands. Use the rests when possible to support the work piece.
- The work piece will get hot as you continue to grind. Cool the work piece frequently using water or another approved solution.
- Change belts frequently to maintain optimal performance.
- Do not force the work piece into the sander.
- Wear the proper protective clothing including safety glasses, face shield, dust masks, earplugs, a leather apron, and heavy leather boots.
- Remember that grinding often produces sparks. DO NOT allow anyone to stand in the path of the sparks. DO NOT grind near flammable materials.
- Concentrate on the task at hand. STOP grinding if you are distracted.
- Make sure the side cover is closed and latched during operation.

BELT TRACKING ADJUSTMENT

When first starting the machine, the belt may not track centrally on the contact wheel.

To adjust the belt tracking:

1. Turn the sander **ON**
2. Making small adjustments, turn the belt tracking adjustment knob clockwise to move the belt to the left, or turn the knob counterclockwise to move the belt to the right.
3. Ensure the belt is not making contact with edge of the sander and that it is centred on the contact wheel.

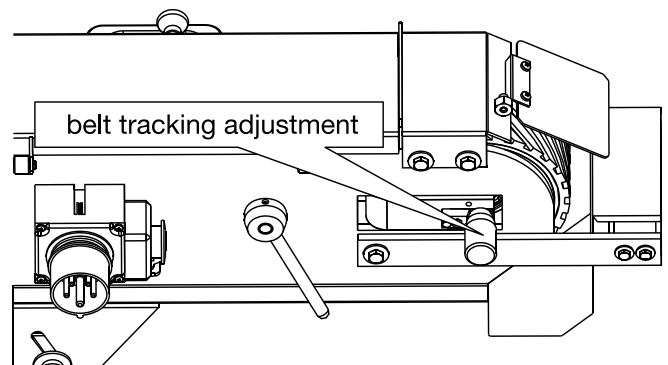

MAINTENANCE

To ensure your machine performs efficiently, follow this maintenance and cleaning schedule and refer to any specific instructions given in this section.

1. Check for and tighten loose mounting bolts.
2. Inspect belts to ensure they are not worn or damaged.
3. Clean chips and debris between platen and sanding belt.
4. Empty spark trap.
5. Sweep surrounding dust and chips.
6. Sweep or vacuum dust and chips from the inside belt compartment and around motor.

It is advisable to replace the lubricating grease of the bearings in the motor of the machine every 6-12 months.

Note: Ensure the machine is switched off and unplugged from the mains power supply before carrying out any maintenance or cleaning.

CHANGING THE BELT

Changing the belt on the machine is quick and easy.

1. Disconnect the sander from the mains power supply.
2. Open the belt guard, remove the spark trap and open the side cover.
3. Loosen the belt by pushing the belt tension lever all the way down and keep in place.
4. Slip the belt off of the wheels and replace with a new belt. Note the correct rotational direction of the belt.
5. Tighten the belt by pulling the belt lever all the way up.
6. Spin the belt by hand to resume previous belt tracking, adjust if necessary.
7. Close and latch the side cover, remount the spark trap, and close the belt guard

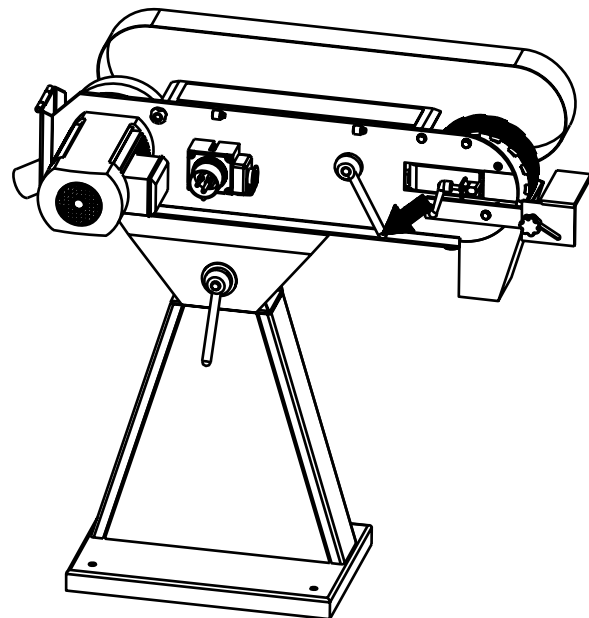

9

MAINTENANCE SAFETY

- Maintenance and repair must be performed by a qualified person. Do not carry out any maintenance work before carefully reading the following instructions.
- While replacing electrical parts of the equipment, turn off the switch and remove the mains power supply.
- Faulty parts should be replaced only with products having the same specifications as the original ones.
- Before performing any maintenance work, turn off the machine and remove the mains power supply. Thus ensuring that the machine is not accidentally activated by another person.
- Maintenance work on electric parts of the equipment should be performed by a qualified technician only.
- Do not clean the machine or its peripheral devices without first removing the mains power supply.
- Keep your fingers in a distance from belts and belt pulleys.
- Do not remove or interfere with safety devices such as covers and limit switches.
- Do not switch the machine on before all safety covers that were removed for maintenance purposes have been replaced.
- Always keep the maintenance area including the working place clean.
- Only use Jefferson approved replacement parts that comply fully with the necessary standards.
- Do not use compressed air to clean the machine or to remove chips.
- Use only specified lubricating oils and grease on the equipment.

TROUBLESHOOTING

Symptom	Possible Causes	Solution
Linisher will not start	<ol style="list-style-type: none"> 1. Equipment unplugged from wall or motor 2. Fuse blown or circuit breaker tripped 3. Cord damaged 	<ol style="list-style-type: none"> 1. Check all plug connections 2. Replace fuse or reset circuit breaker 3. Replace cord
Sanding belt does not come up to speed	<ol style="list-style-type: none"> 1. Extension cord too light or too long 2. Motor not wired for proper voltage 3. Low current 	<ol style="list-style-type: none"> 1. Replace with adequate size and length cord 2. Refer to motor junction cover for proper wiring 3. Contact a qualified electrician
Machine vibrates excessively	<ol style="list-style-type: none"> 1. Stand on uneven floor 2. Motor mounts are loose 3. Tension spring is worn or broken 	<ol style="list-style-type: none"> 1. Adjust stand so that it rests evenly on the floor 2. Tighten motor mount bolts 3. Replace spring
Abrasive belt keeps tearing	<ol style="list-style-type: none"> 1. Belt is running in the wrong direction 	<ol style="list-style-type: none"> 1. Arrow on the sanding belt and machine should be pointing in the same direction.
Sanded edge not square	<ol style="list-style-type: none"> 1. Table not square to sanding plate 	<ol style="list-style-type: none"> 1. Use a square to adjust table to sanding plate
Sanding marks on wood	<ol style="list-style-type: none"> 1. Work held still 2. Wrong grit sanding belt 3. Feed pressure too great 4. Sanding against the grain 	<ol style="list-style-type: none"> 1. Keep work piece moving 2. Use coarser grit for stock removal and fine grit for finish sanding. 3. Never force work into sanding platen 4. Sand with the grain

CIRCUIT / WIRING DIAGRAM

WIRE DIAGRAM (230V~,50Hz, 1-SPEED)

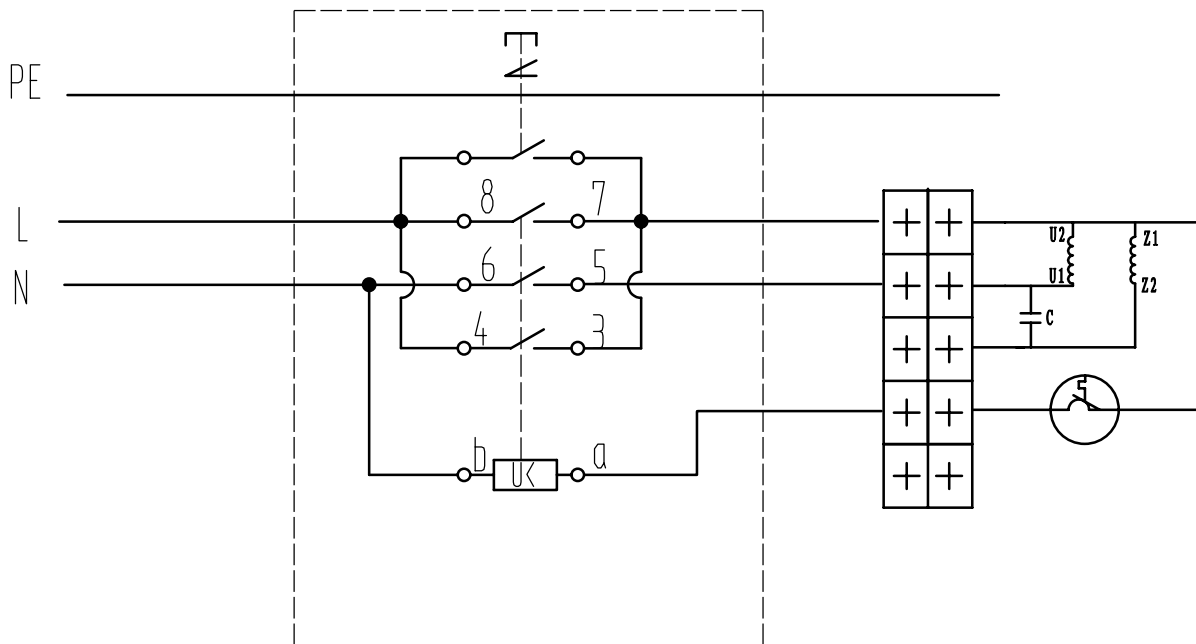

WIRE DIAGRAM (400V,3~,50Hz, 1-SPEED)

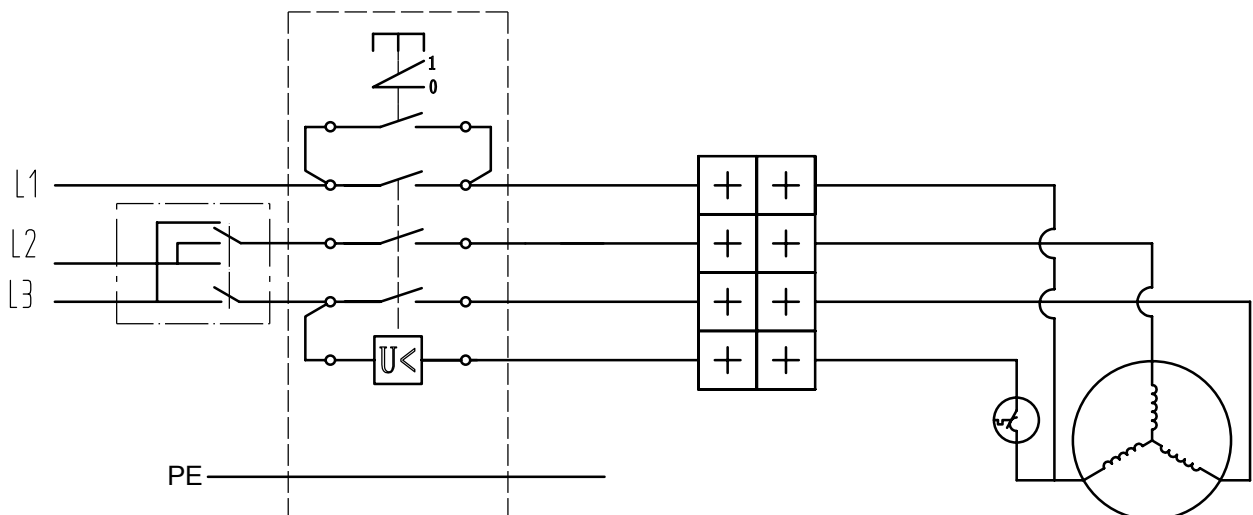

PARTS DIAGRAM - JEFBLTSND075-230 • JEFBLTSND75-400

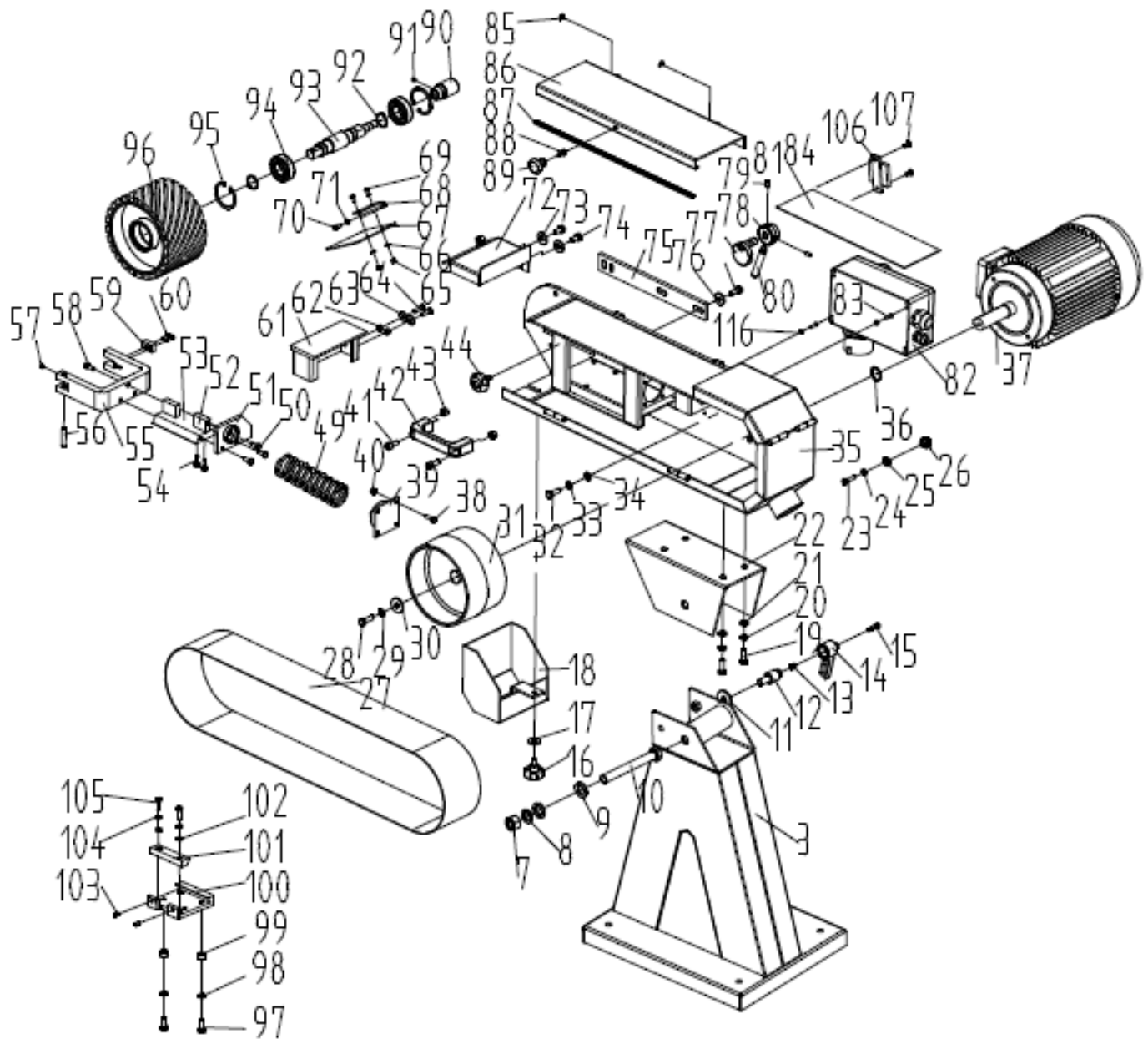

PARTS LIST - JEFBLTSND075-230 • JEFBLTSND075-400

#	Description	#	Description
3	STAND BASE	59	BEVEL BLOCK
7	HEX NUT M16	60	HEX BOLT M5X16
8	SPRING WASHER 16	61	TABLE
9	WASHER 16	62	HEX NUT M6
10	HEX BOLT M16X160	63	BIG WASHER 6
11	BIG WASHER 12	64	HEX BOLT M6X20
12	ANGLE ADJUSTMENT LEVER	65	HEX NUT M5
13	SPRING	66	WASHER 5
14	LOCKING HANDLE	67	EYE SHIELD
15	STEP SCREW	68	BRACKET
16	LOCKING KNOB	69	SCREW M5X10
17	BIG WASHER 8	70	SCREW M5X12
18	SPARK TRAP	71	WASHER 5
19	HEX BOLT M10X25	72	REAR SHIELD
20	SPRING WAHSER10	73	BIG WASHER 8
21	WASHER10	74	HEX BOLT M8X12
22	PIVOT BASE	75	TABLE SET PLATE
23	HEX BOLT M6X25	76	BIG WASHER 8
24	SPRING WASHER 6	77	HEX BOLT M8X20
25	BIG WASHER 6	78	ECCENTRIC WHEEL
26	LOCKING BUTTON	79	HANDLE REST
27	SANDER BELT	80	HANDLE
28	HEX BOLT M8X25	81	SET SCREW M6X12
29	SPRING WASHER 8	82	SWITCH BOX
30	BIG WASHER 8	83	SCREW M4X16
31	DRIVE WHEEL	84	PLUMBAGINOUS BOARD
32	HEX BOLT M8X25	85	E-RING RETAINING RING
33	SPRING WASHER 8	86	ACTIVE COVER
34	WASHER 8	87	SHOCK ABSORPTION PIECE
35	BODY	88	HEX BOLT M6X12
36	CIRCLIP FOR SHAFTS 24	89	HAND BALL
37	MOTOR	90	BELT TRACKING ADJUSTMENT KNOB
38	HEX BOLT M6X20	91	SET SCREW M6X6
39	SPRING PLATE	92	CIRCLIP FOR SHAFTS 25
40	HEX NUT M6	93	GUIDE PULLEY SPINDLE
41	SCREW M8X20	94	BEARING 6205
42	GRIPE	95	CIRCLIP FOR BORES 52
43	HEX NUT M8	96	CONTACT WHEEL
44	LOCKING KNOB	97	HEX BOLT M8X20
49	SPRING	98	SPRING WASHER 8
50	HEX BOLT M6X16	99	SPACE BUSH
51	SPRING PLATE	100	SUPPORT
52	LINK PLATE	101	DISTANCE STRIP
53	GUIDE PLATE	102	WASHER 6
54	SCREW M6X16	103	SCREW M6X10
55	GUIDE BELT REST	104	SPRING WASHER 6
56	PIN 8X40	105	HEX BOLT M6X20
57	SET SCREW M6X8	106	PROTECTIVE PLATE
58	SCREW M6X16	107	SCREW M6X12

PARTS DIAGRAM - JEFBLTSND150-230 • JEFBLTSND150-400

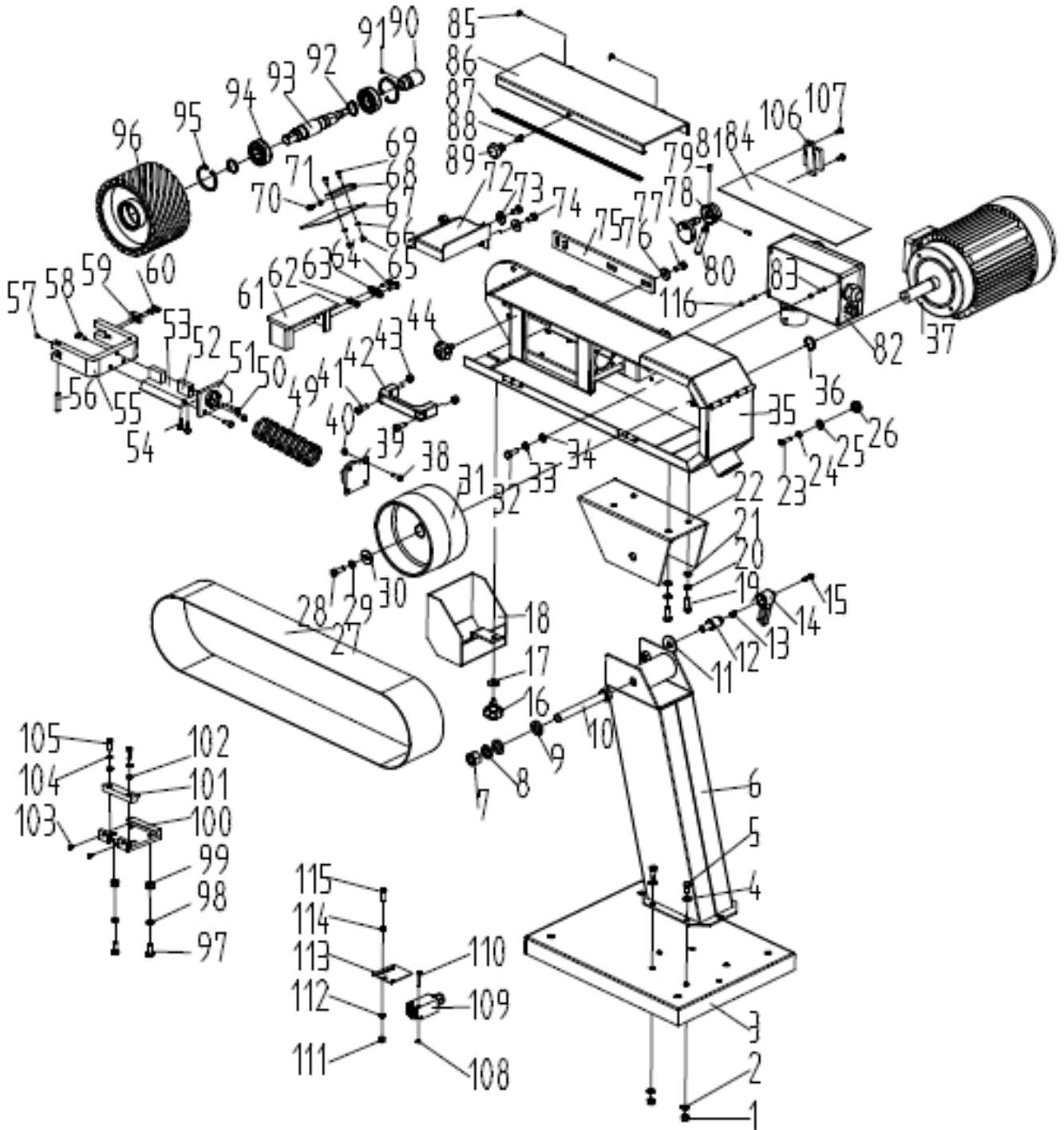

PARTS LIST - JEFBLTSD150-230 • JEFBLTSD150-400

#	Description	#	Description	#	Description
1	HEX NUT M8	41	SCREW M8X20	81	SET SCREW M6X12
2	WASHER 8	42	GRIPE	82	SWITCH BOX
3	STAND BASE	43	HEX NUT M8	83	SCREW M4X16
4	WASHER 8	44	LOCKING KNOB	84	PLUMBAGINOUS BOARD
5	HEX BOLT M8 x 16	45	N/A	85	E-RING RETAINING RING
6	SQUARE TUBE	46	N/A	86	ACTIVE COVER
7	HEX NUT M16	47	N/A	87	SHOCK ABSORPTION PIECE
8	SPRING WASHER 16	48	N/A	88	HEX BOLT M6X12
9	WASHER 16	49	SPRING	89	HAND BALL
10	HEX BOLT M16 x 160	50	HEX BOLT M6X16	90	BELT TRACKING ADJUSTMENT KNOB
11	BIG WASHER 12	51	SPRING PLATE	91	SET SCREW M6X6
12	ANGLE ADJUSTMENT LEVER	52	LINK PLATE	92	CIRCLIP FOR SHAFTS 25
13	SPRING	53	GUIDE PLATE	93	GUIDE PULLEY SPINDLE
14	LOCKING HANDLE	54	SCREW M6X16	94	BEARING 6205
15	STEP SCREW	55	GUIDE BELT REST	95	CIRCLIP FOR BORES 52
16	LOCKING KNOB	56	PIN 8X40	96	CONTACT WHEEL
17	BIG WASHER 8	57	SET SCREW M6X8	97	HEX BOLT M8X20
18	SPARK TRAP	58	SCREW M6X16	98	SPRING WASHER 8
19	HEX BOLT M10 x 25	59	BEVEL BLOCK	99	SPACE BUSH
20	SPRING WASHER 10	60	HEX BOLT M5X16	100	SUPPORT
21	WASHER 10	61	TABLE	101	DISTANCE STRIP
22	PIVOT BASE	62	HEX NUT M6	102	WASHER 6
23	HEX BOLT M6X25	63	BIG WASHER 6	103	SCREW M6X10
24	SPRING WASHER 6	64	HEX BOLT M6X20	104	SPRING WASHER 6
25	BIG WASHER 6	65	HEX NUT M5	105	HEX BOLT M6X20
26	LOCKING BUTTON	66	WASHER 5	106	PROTECTIVE PLATE
27	SANDER BELT	67	EYE SHIELD	107	SCREW M6X12
28	HEX BOLT M8X25	68	BRACKET	108	HEX NUT M4
29	SPRING WASHER 8	69	SCREW M5X10	109	Interlocking switch
30	BIG WASHER 8	70	SCREW M5X12	110	SCREW M4X30
31	DRIVE WHEEL	71	WASHER 5	111	LOCKING NUT M6
32	HEX BOLT M8X25	72	REAR SHIELD	112	WASHER 6
33	SPRING WASHER 8	73	BIG WASHER 8	113	PLATE
34	WASHER 8	74	HEX BOLT M8X12	114	HEX NUT M6
35	BODY	75	TABLE SET PLATE	115	SCREW M6X25
36	CIRCLIP FOR SHAFTS 24	76	BIG WASHER 8	116	HEX NUT M4
37	MOTOR	77	HEX BOLT M8X20		
38	HEX BOLT M6X20	78	ECCENTRIC WHEEL		
39	SPRING PLATE	79	HANDLE REST		
40	HEX NUT M6	80	HANDLE		

ENVIRONMENTAL PROTECTION



**PLEASE
RECYCLE**

Recycle any packaging and unwanted materials instead of disposing of them as waste. All tools, accessories and packaging should be sorted, taken to a recycling centre and disposed of in a manner which is compatible with the environment.

When the product becomes completely unserviceable, reaches the end of its working life and requires disposal, drain off any fluids (if applicable) into approved containers and dispose of the product and the fluids according to local regulations.

WEEE Waste Electrical and Electronic Equipment Statement

INFORMATION ON DISPOSAL FOR USERS OF WASTE ELECTRICAL & ELECTRONIC EQUIPMENT



This symbol on the product(s) and / or accompanying documents means that used electrical and electronic products should not be mixed with general household waste. For proper treatment, recovery and recycling, please take this product(s) to designated collection points where it will be accepted free of charge.

FOR PRIVATE HOUSEHOLDS:

Dispose of this product at the end of its working life and in compliance with the EU Directive on Waste Electrical and Electronic Equipment (WEEE). Contact your local solid waste authority for recycling information for this equipment.

16

Disposing of this product correctly will help save valuable resources and prevent any potential negative effects on human health and the environment, which could otherwise arise from inappropriate waste handling.

Please contact your local authority for further details of your nearest designated collection point.

Penalties may be applicable for incorrect disposal of this waste, in accordance with your national legislation.

FOR BUSINESS USERS IN THE EUROPEAN UNION:

If you wish to discard electrical and electronic equipment, please contact your dealer or supplier for further information.

INFORMATION ON DISPOSAL IN OTHER COUNTRIES OUTSIDE THE EUROPEAN UNION:

This symbol is only valid in the European Union. If you wish to discard this product please contact your local authorities or dealer and ask for the correct method of disposal.

RoHS Directive 2011/65/EU

We hereby declare that this equipment has been tested and found to be compliant to RoHS Directive 2011/65/EU of the European Parliament and the Council from 08/06/2011 on restriction of the use of certain hazardous substances in electrical and electronic appliances.

Determination of levels of regulated substances in electrotechnical products, elements of Cadmium (Cd), Lead (Pb), Mercury (Hg), Chromium (Cr) and Bromine (Br) contents were measured by XRF Spectroscopy and chemical confirmation test for RoHS restricted substances.

EC DECLARATION OF CONORMITY

We, Jefferson Professional Tools & Equipment, as the authorised European Community representative of the manufacturer, declare that the following equipment conforms to the requirements of the following:

Directive / Standard / Regulation	Description:
2006/42/EC (as amended)	Machinery Directive
EN ISO 12100:2010	Safety of machinery — General principles for design — Risk assessment and risk reduction
EN 60204-1:2006/A1:2009	Electrical Safety of Machines

Equipment Category: Belt Linisher / Metal Belt Sander

Notified Testing Body: TÜV SÜD Certification and Testing (China) Co., Ltd. Beijing Branch

Model Number(s):
 JEFBLTSND075-230
 JEFBLTSND075-400
 JEFBLTSND150-230
 JEFBLTSND150-400

17

Level of acoustic power A (LWA)
 LWA = 94.5 dB(A) (No-load)
 LWA = 103 dB(A) (Load)

Signed by: Stephen McIntyre

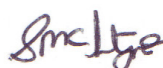

Position in the company: Operations Director

Date: 06 October 2023

Name and address of manufacturer or authorised representative:
Jefferson Professional Tools & Equipment
 24 Lisgorgan Lane,
 Upperlands,
 BT46 5TE
Telephone: +44 (0)1244 646 048 (UK) +353 (0)1473 0300 (ROI)
Email: enquiries@jeffersonstools.com

LIMITED WARRANTY STATEMENT

Jefferson Professional Tools & Equipment, or hereafter "Jefferson" warrants its customers that its products will be free of defects in workmanship or material. Jefferson shall, upon suitable notification, correct any defects, by repair or replacement, of any parts or components of this product that are determined by Jefferson to be faulty or defective.

This warranty is void if the equipment has been subjected to improper installation, storage, alteration, abnormal operations, improper care, service or repair.

Warranty Period

Jefferson will assume both the parts and labour expense of correcting defects during the stated warranty periods below.

All warranty periods start from the date of purchase from an authorised Jefferson dealer. If proof of purchase is unavailable from the end user, then the date of purchase will be deemed to be 3 months after the initial sale to the distributor.

1 Year

Jefferson Belt Linishers: JEFBLTSND075-230 • JEFBLTSND075-400 • JEFBLTSND150-230 • JEFBLTSND150-400

90 Days

• All replacement parts purchased **outside** of the warranty period

Important: All parts used in the repair or replacement of warranty covered equipment will be subject to a minimum of 90 days cover or the remaining duration of the warranty period from the original date of purchase.

Warranty Registration / Activation

You can register and activate your warranty by visiting the Jefferson Tools website using the following address:

www.jeffersontools.com/warranty and completing the online form. Online warranty registration is recommended as it eliminates the need to provide proof of purchase should a warranty claim be necessary.

18

Warranty Repair

Should Jefferson confirm the existence of any defect covered by this warranty the defect will be corrected by repair or replacement at an authorized Jefferson dealer or repair centre.

Packaging & Freight Costs

The customer is responsible for the packaging of the equipment and making it ready for collection. Jefferson will arrange collection and transportation of any equipment returned under warranty. Upon inspection of the equipment, if no defect can be found or the equipment is not covered under the terms of the Jefferson warranty, the customer will be liable for any labour and return transportation costs incurred. These costs will be agreed with the customer before the machine is returned.

* Jefferson reserve the right to void any warranty for damages identified as being caused through misuse

Warranty Limitations

Jefferson will not accept responsibility or liability for repairs made by unauthorised technicians or engineers. Jefferson's liability under this warranty will not exceed the cost of correcting the defect of the Jefferson products.

Jefferson will not be liable for incidental or consequential damages (such as loss of business or hire of substitute equipment etc.) caused by the defect or the time involved to correct the defect. This written warranty is the only express warranty provided by Jefferson with respect to its products.

Any warranties of merchantability are limited to the duration of this limited warranty for the equipment involved.

Jefferson is not responsible for cable wear due to flexing and abrasion. The end user is responsible for routine inspection of cables for possible wear and to correct any issues prior to cable failure.

Claiming Warranty Coverage

The end user must contact Jefferson Professional Tools & Equipment (Tel: +44 (0) 1244 646 048) +353 (0)1473 0300 (ROI) or their nearest authorised Jefferson dealer where final determination of the warranty coverage can be ascertained.

Step 1 - Reporting the Defect

Online Method:

- Visit our website www.jeffersonstools.com/warranty and complete the Warranty Returns form. You can complete the form online and submit it to us directly or download the form to print out and return by post.

Telephone Method:

Contact your Jefferson dealer or sales representative with the following information:

- Model number
- Serial number (usually located on the specification plate)
- Date of purchase

A Warranty Returns form will be sent to you for completion and return by post or fax, together with details of your nearest authorised Jefferson repair centre. On receipt of this form Jefferson will arrange to collect the equipment from you at the earliest convenience.

Step 2 - Returning the Equipment

It is the customer's responsibility to ensure that the equipment is appropriately and securely packaged for collection, **together with a copy of the original proof of purchase**. Please note that Jefferson cannot assume any responsibility for any damage incurred to equipment during transit. Any claims against a third party courier will be dealt with under the terms & conditions of their road haulage association directives.

NOTE: Jefferson will be unable to collect or process any warranty requests without a copy of the original proof of purchase.

Step 3 - Assessment and Repair

On receipt, the equipment will be assessed by an authorised Jefferson engineer and it will be determined if the equipment is defective and in need of repair and any repairs needed are covered by the warranty policy. In order to qualify for warranty cover all equipment presented must have been used, serviced and maintained as instructed in the user manual. **19**

Where repair is not covered by the warranty a quotation for repair, labour costs and return delivery will be sent to the customer (normally within 7 working days).

NOTE: If the repair quotation is not accepted Jefferson Professional Tools & Equipment will invoice **1 hour labour time at £30 per hour plus return carriage costs (plus VAT)**.

In cases where no fault can be found with the equipment, or, if incorrect operation of the equipment is identified as the cause of the problem, a minimum of 1 hour labour at **£30 per hour plus carriage costs** will be required before the equipment will be despatched back to the customer.

Any equipment repaired or replaced under warranty will normally be ready for shipment back to the customer within 7 working days upon receipt of the equipment at an authorised Jefferson Repair centre (subject to part availability). Where parts are not immediately available Jefferson will contact you with a revised date for completion of the repair.

General Warranty Enquiries

For any further information relating to Jefferson warranty cover please call **+44 (0) 1244 646 048(UK)** **+353 (0)1473 0300 (ROI)** or send your enquiry via email to **warranty@jeffersonstools.com**

Disclaimer:

The information in this document is to the best of our knowledge true and accurate, but all recommendations or suggestions are made without guarantee. Since the conditions of use are beyond their control, Jefferson Tools® disclaim any liability for loss or damage suffered from the use of this data or suggestions. Furthermore, no liability is accepted if use of any product in accordance with this data or suggestions infringes any patent. Jefferson Tools® reserve the right to change product specifications and warranty statements without further notification. All images are for illustration purposes only.

IMPORTANT! SAFETY FIRST!

Before attempting to use this product please read all the safety precautions and operating instructions outlined in this manual to reduce the risk of fire, electric shock or personal injury.

Jefferson[®]
PROFESSIONAL TOOLS & EQUIPMENT

Jefferson Professional Tools & Equipment
24 Lisgorgan Lane, Upperlands, BT46 5TE

Tel: +44 (0)1244 646 048 (UK)
+353 (0)1473 0300 (ROI)

Email: info@jeffersontools.com

www.jeffersontools.com