

Jefferson®

200mm Bench Grinder

500W / ¾Hp • 2850rpm • 230V / 50Hz



JEFBGS08

USER MANUAL

www.jeffersonstools.co.uk

Table of Contents

1. Technical Specifications	page 2
2. General Safety Guidelines	page 2
3. Box Contents / Machine Parts Itinerary	page 3
4. Parts Identified	page 3
5. Assembly Instructions	page 4
6. Operating Instructions	page 8
7. Maintenance	page 8
8. Troubleshooting Guide	page 9
9. Parts Diagram	page 11
10. Parts List	page 12
11. Declaration of Conformity	page 13

 **Warning:** Please read all safety instructions carefully before use to avoid the risk of accident or personal injury.

1. Technical Specifications

Model:	JEFBGS08
Motor Type:	Induction
Input Power:	230V / 50Hz:
Output Power:	550W (¾HP)
Wheel Diameter:	8" (200mm)
Wheel Width:	1" (25mm)
Arbor Hole:	5/8" (15.88mm)
No Load Speed:	2850rpm
Wheel Grits:	36 (Course) 60 (Course)

2. General Safety Guidelines:

A. Personal Protection:

- Always suitable eye protection when using this equipment and ensure protection level is sufficient for the work being undertaken.
- Always wear a dust mask or respirator when dusty is generated.
- Never operate this equipment wearing loose clothing or jewellery - keep long hair tied back.
- Never use the equipment when tired or under the influence of drugs, alcohol or medication.
- Keep hands clear of the driving wheels at all times.
- Never reach behind or beneath the grinding wheels when the grinder is running.

Please note: The grinding wheels will continue to rotate after the tool is switched off - it is important that you allow the wheels to stop fully before carrying out any work on the equipment.

B. Storage and Working Environment:

- This equipment is designed for indoor use in well-lit, dry and well ventilated environments. Do not use in damp conditions to avoid electric shock.
- Keep children and bystanders out of the work area when the tool is in operation.
- This equipment can generate sparks when in use so it is important that you ensure that the work area kept clear of all flammable materials, liquids and gasses.

C. Equipment Safety:

- Check that the power switch is set to the "Off" position before connecting it to the mains power supply.
- Always ensure that all grinding wheel lock nuts, securing bolts, clamps and guards are tightened and secure before operation.
- Always disconnect this equipment from the power supply before carrying out any adjustments or maintenance.
- This equipment is designed for indoor use in well-lit, dry and well ventilated environments. Do not use in damp conditions to avoid electric shock.
- Keep all guards in place and in good condition.
- Replace cracked, damaged or worn grinding wheels immediately.
- When fitting a new grinding wheel, always check that the RPM is equal or lesser than the RPM stated on the grinder. Ensure that the new wheel is free from damage or flaws before fitting.
 - During start-up, stand to one side of the grinder and switch to the "On" position. Let the grinder operate at full speed for approximately one minute to allow any undetected flaws or cracks become apparent.
- Ensure that all accessories are compatible with this model or recommended by the manufacturer.
- Never attempt to cut anything with the grinding wheel.
- Never overtighten spindle nuts.
- All service and maintenance tasks on this equipment should be carried out by authorised and qualified technicians.
- Adjust tool rests whenever necessary to maintain a distance of 1/8" (32mm) from the grinding wheel.

D. Electrical Safety:

- Ensure that all cables & plugs are in good condition before use.
- Ensure that the equipment is grounded before use. Grounding helps to ensure that the current will take the path of least resistance in the event of an electrical malfunction or short circuit thereby reducing the risk of electric shock for the operator.
- This machine is equipped with an electrical cord that has an equipment grounding conductor and a grounding plug. The plug must be plugged into a compliant outlet that has been properly installed and grounded in accordance with current specifications and ordinances.
- Never modify the plug provided. If it does not fit the outlet ensure that the correct outlet is installed by a qualified technician.

E. Using Extension Cables

- Ensure that all extension cables are compatible for use with the tool and that they are correctly wired and free from wear and damage.
 - Ensure that the extension cords are heavy enough to carry the current drawn by this equipment. If the extension cable is not heavy enough - a drop in voltage can occur - resulting in loss of power and overheating and damage to the motor that is not covered under warranty.

3. Box Contents / Machine Parts Itinerary

ITEM	QTY
Left Work Rest	1
Right Work Rest	1
Plain Eye Shield	1
Eye Shield Fixing Knob	1
Eye Shield Mounting Rod (1 left, 1 right)	2
Eye Shield Assembly Mounting Bolt M6x30	2
Eye Shield Assembly Mounting Washer D6	2
Eye Shield Assembly Mounting Locking Washer D6	2
Work Rest Fixing Knob	2
Work Rest Fixing Pain Washer D5	2
Work Rest Fixing Locking Washer D5	2
Coolant Tray	1
Spark Deflector	2
Spark Deflector Fixing Screw Assembly	2

4. Parts Identified

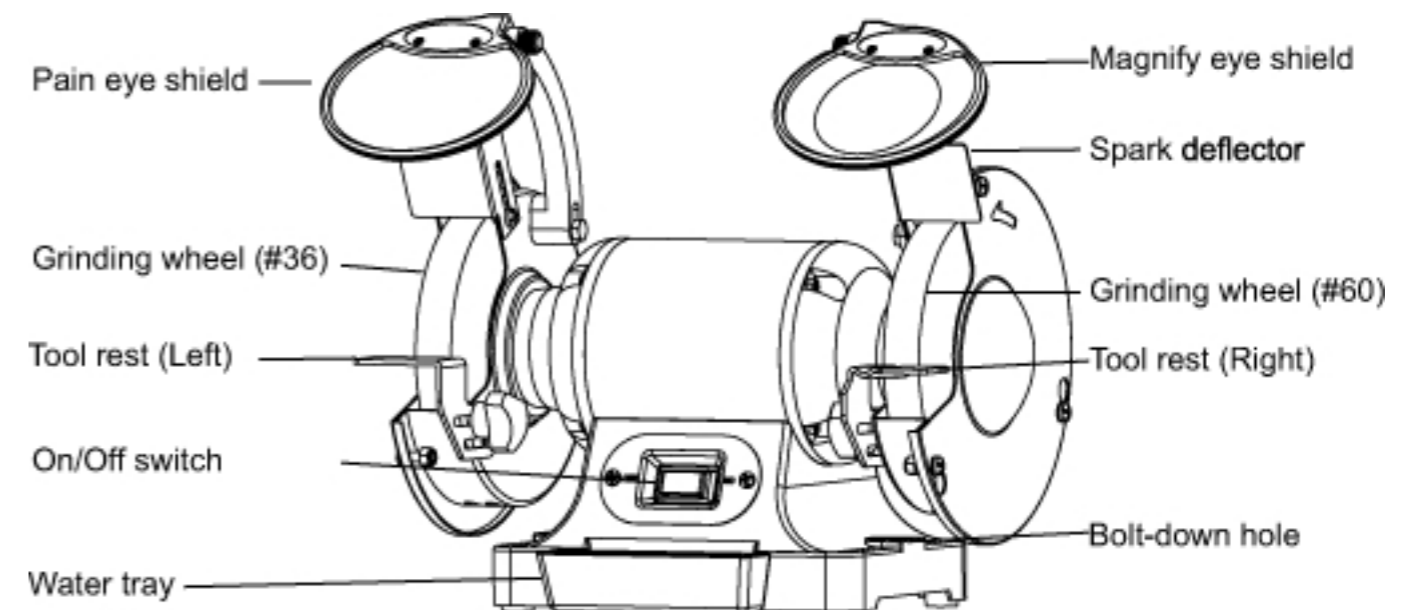

Fig.1 - Parts

5. Assembly Instructions

A. Mounting the Grinder to the Workbench

Before using the grinder it is essential that you first mount it to a work bench or grinding stand/pedestal.

Caution: Bench grinders vibrate. Grinder movement during high-speed rotation may cause injury or damage to the workpiece or operator.

1. Position the grinder on the workbench
2. Mark the workbench through the two mounting holes located in the grinder base.
3. Drill holes in the workbench at the marks
4. Using two long bolts, lock bolts, lock-washers and nuts (parts not supplied) secure the grinder to the workbench as shown in **Fig.2**.

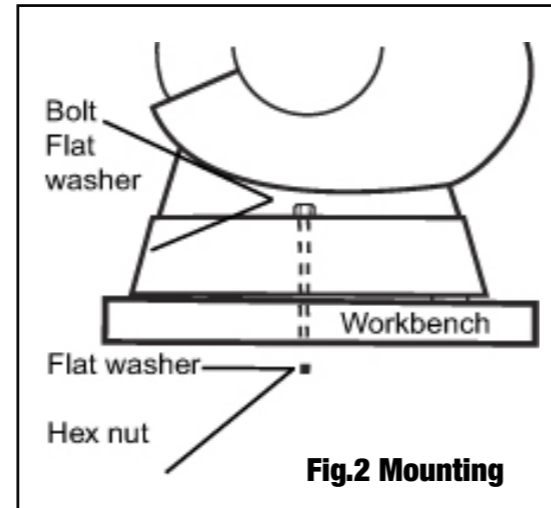

B. Eye Shield Assembly

Eye shields must be installed before using this equipment.

1. Mount the left and right shield rods to the inside of the wheel guards using the hex mounting bolts (M6x30) provided.
2. Once the shield rods are firmly in place, slide the shield bracket onto the shield rod.
3. Tighten the carriage bolt, leaving it loose enough to allow the safety shield to be raised and lowered easily.

Note: The eye shield should move freely when adjusted but stay fixed when the locking knob is tightened.

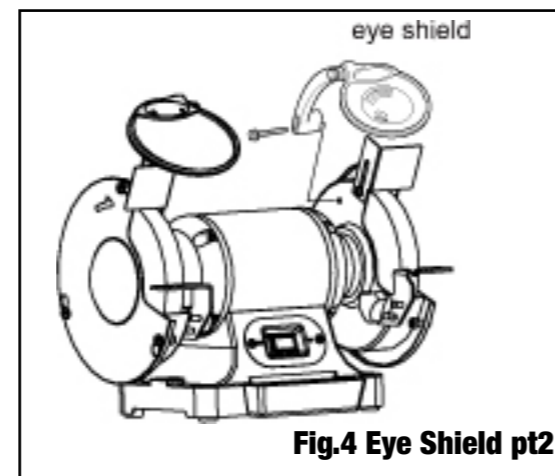
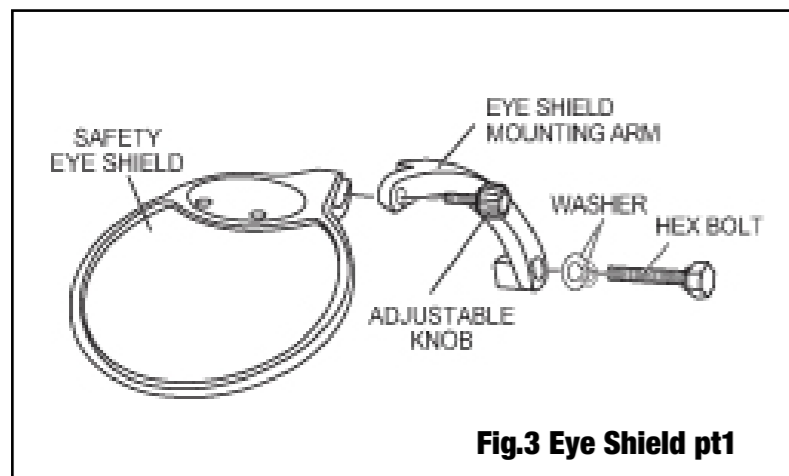

5. Assembly Instructions (continued)

Warning: Ensure that the machine is powered down and disconnected from the mains supply before making any changes to the grinding wheel. When using the grinder immediately following a wheel installation/change ensure that you stand to the side of the grinder (never in front) and allow the grinder to run for at least one minute before proceeding to use it.

Never install or use a damaged grinding wheel.

C. Installing or Changing the Grinding Wheel

1. Use a screwdriver to loosen the wheel cover screws and push anti-clockwise to remove the wheel cover
2. Fit an appropriately sized wrench on the spindle hex nut
3. Loosen the wheel nut in a clockwise direction for the left side and counter-clockwise direction for the right side.
4. Remove the outer flange and the grinding wheel. To remove the hex nut, turn the wrench and the nut until the wrench is resting on the workbench behind the tool.
5. Inspect the new wheel carefully to ensure that there are no cracks, chips or other damage.
6. Wipe the flange surfaces clean and install the new wheel, flange and spindle hex nut. (never overtighten this nut to avoid cracking the wheel.)
7. To install a new grinding wheel, reverse the above procedure.
8. Be sure that the grinding wheel and outer flange are properly seated on the spindle shaft.
9. Replace the wheel cover and reposition the tool rest.

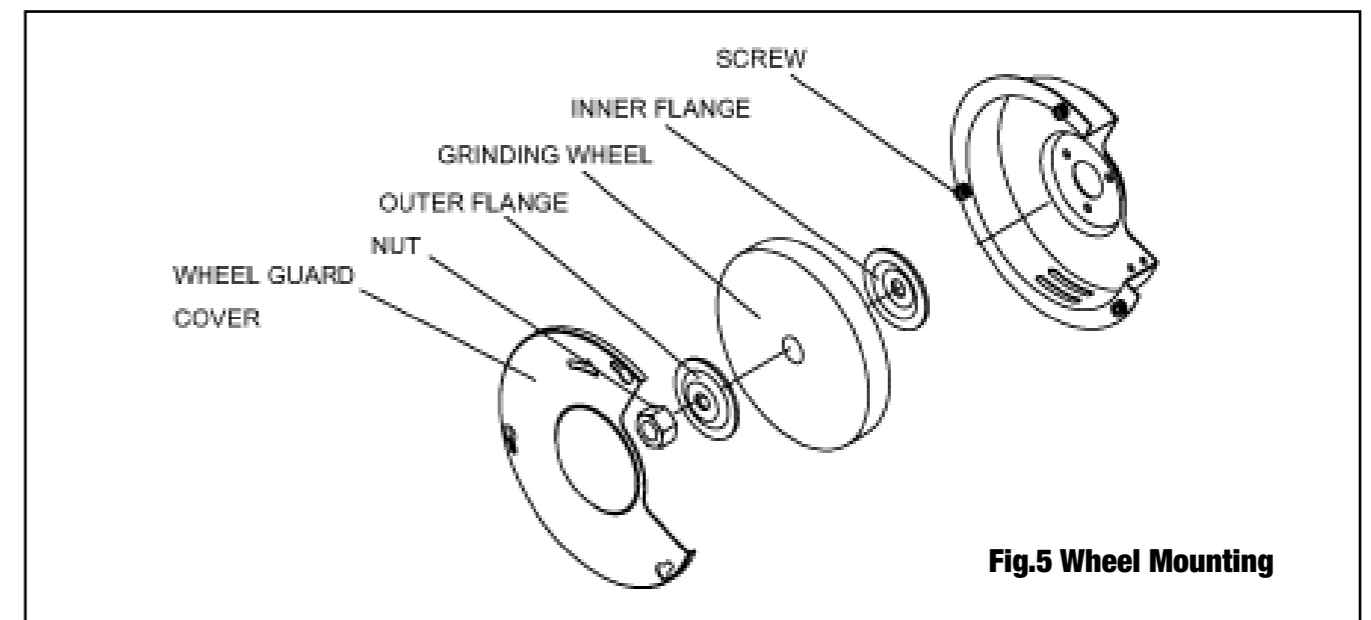

5. Assembly Instructions (continued)

D. (i) Tool Rest Assembly

1. Mount the tool rests to the work rest bracket using the knob and washers provided.
2. Before tightening the knob, adjust the gap between the grinding wheel and the work rest to a maximum of 1/8" (32mm) - tighten securely.

D. (ii) Tool Rest Adjustments

In order to prevent the workpiece from being pulled and caught between the tool rest and the wheel, readjust the tool rest position whenever necessary to maintain the 1/8" (3.2mm) distance.

1. Loosen, but do not remove, the knob holding the tool rest arm.
2. Slide the tool rest in or out to achieve a 1/8" (32mm) distance from the grinding wheel surface.
3. Re-tighten the locking knob.

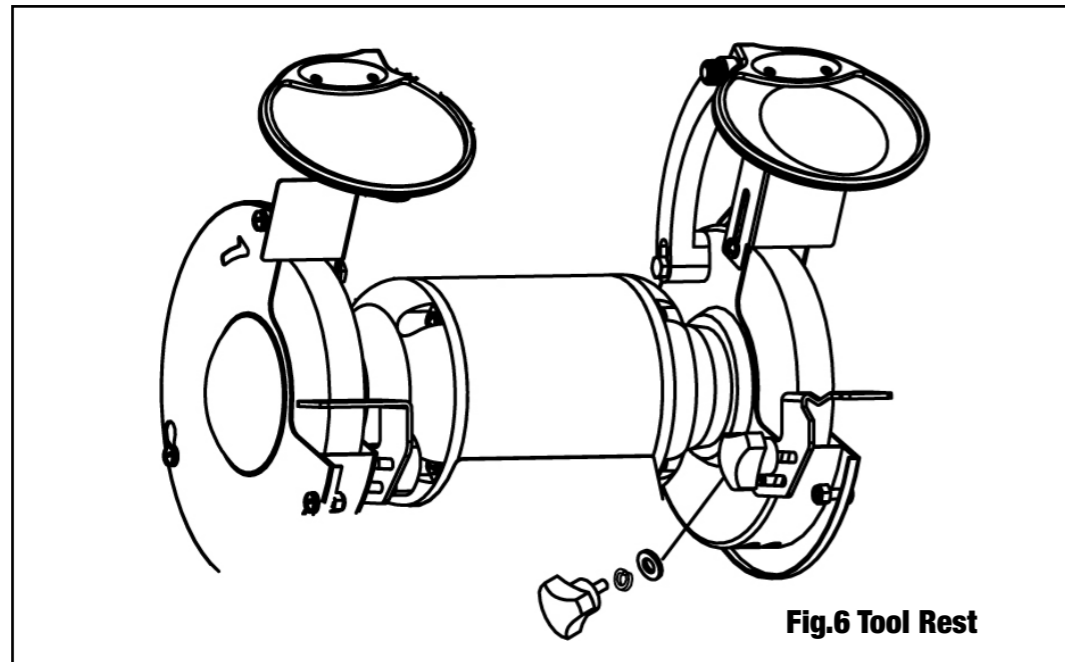

6. Operating Instructions

This tool is designed for sharpening chisels, axes and other wood cutting tools. It is also useful for repairing tips on screwdrivers and drill bits and removing excess metal burrs from pieces of cut metal. With the proper accessories, the tool can be used for cleaning metal surfaces using a wire brush or for buffing and polishing using a cloth wheel.

A. Turning the Grinder On/Off

The On/Off power switch is located on the front of the grinder.

B. Grinding Guidelines

- Adjust the tool rest to accommodate large or unusually shaped work pieces.
- Always keep the workpiece moving across the face of the grinding wheel. Grinding continuously on the same spot on the wheel will result in excessive wearing and grooving on the grinding surface. This in turn can lead to a greater risk of wheel damage and reduction in grinding quality.
- If the workpiece becomes hot - dip it in water or oil to cool it.
- Always grind on the face of the wheel (around the diameter), never on the sides. Side pressure on grinding wheels can cause cracking and damage.
- If the face of the grinding wheel is worn unevenly, becomes grooved, or is no longer smooth and flat, the wheel should be reshaped with a dressing tool (not provided). If cannot be reshaped it should be replaced.
- If the surface of the wheel becomes loaded or dulled with waste workpiece particles or debris the wheel should be cleaned with a dressing tool.
 - After reshaping, always readjust the tool rests and spark arrestors.
- When grinding metal objects can be heated quickly, keep the workpiece moving back and forth across the face of the grinding wheel and cool the object frequently using the coolant tray

7. Maintenance

Task	Frequency
Check the power cord	Before each use
Check the wheels for cracks	Before each use
Check all moving parts for alignment and binding issues	Before each use
Dress grinding wheels	As required
Replace the grinding wheels	As required
Clean and vacuum dust from the motor housing & other parts	As required

Warning: Any service beyond the recommended maintenance tasks listed above should only be carried out by a trained technician.

8. Troubleshooting Guide

Problem / Symptom	Cause	Action
Motor will not start.	<ol style="list-style-type: none"> 1. Low voltage 2. Open circuit in motor or loose connections 3. Blown fuse or circuit breaker 	<ol style="list-style-type: none"> 1. Check power source / ensure correct voltage is used 2. Inspect all cable connections on the motor for loose or open connections. Send for servicing. 3. Ensure that circuit breaker and fuse are compatible with power rating stated on nameplate. Send for servicing.
Motor will not start - fuses or circuit breakers tripping or blowing.	<ol style="list-style-type: none"> 1. Short circuit in line, cord or plug. 2. Short circuit in motor or loose connections. 3. Incorrect fuses or circuit breakers in the power line. 	<ol style="list-style-type: none"> 1. Inspect the cord or plug for damaged insulation and shorted wires. 2. Inspect all connections on the motor for loose or shorted terminals and/or worn insulation. 3. Install correct fuses or circuit breakers. Move the tool onto a compatible circuit.
Motor overheating.	<ol style="list-style-type: none"> 1. Motor overloaded. 2. Extension cable too long or not heavy enough. 	<ol style="list-style-type: none"> 1. Reduce load on the motor. 2. Use a compatible extension cable for the machine rating.
Motor stalling (resulting in blown fuses or tripping).	<ol style="list-style-type: none"> 1. Short circuit in line, cord or plug. 2. Short circuit in motor or loose connections. 3. Incorrect fuses or circuit breakers in the power line. 4. Motor overloaded. 	<ol style="list-style-type: none"> 1. Check power source / ensure correct voltage is used 2. Inspect all cable connections on the motor for loose or open connections. Send for servicing. 3. Ensure that circuit breaker and fuse are compatible with power rating stated on nameplate. Send for servicing. 4. Reduce load on the motor.
Machine slows while operating.	<ol style="list-style-type: none"> 1. Feed rate is too high 	<ol style="list-style-type: none"> 1. Reduce the feed rate to the grinding wheel.

8. Troubleshooting Guide (continued)

Problem / Symptom	Cause	Action
Wavy patterning on the surface of the workpiece.	<ol style="list-style-type: none"> 1. Machine vibrating. 2. Workpiece not being held firmly. 3. Uneven wheel face. 4. Wheel is too hard. 	<ol style="list-style-type: none"> 1. Ensure that the wheel is securely mounted on a solid surface. 2. Use a holding device to retain the workpiece firmly. 3. Dress the grinding wheel. 4. Use a softer wheel or reduce the feed rate.
Lines on the surface of the workpiece.	<ol style="list-style-type: none"> 1. Impurity on the wheel surface. 2. Workpiece not being held firmly. 	<ol style="list-style-type: none"> 1. Dress/clean the grinding wheel. 2. Use a softer wheel or reduce the feed rate.
Burning spots or cracks on the workpiece. Wheel is dull / clogged.	<ol style="list-style-type: none"> 1. Incorrect grinding wheel. 2. Incorrect feed rate. 3. Coolant required. 	<ol style="list-style-type: none"> 1. Use wheel with softer bond or coarser grit. 2. Reduce feed rate. 3. Use coolant more regularly. 4. Dress / clean / replace the wheel.

9. Parts Diagram

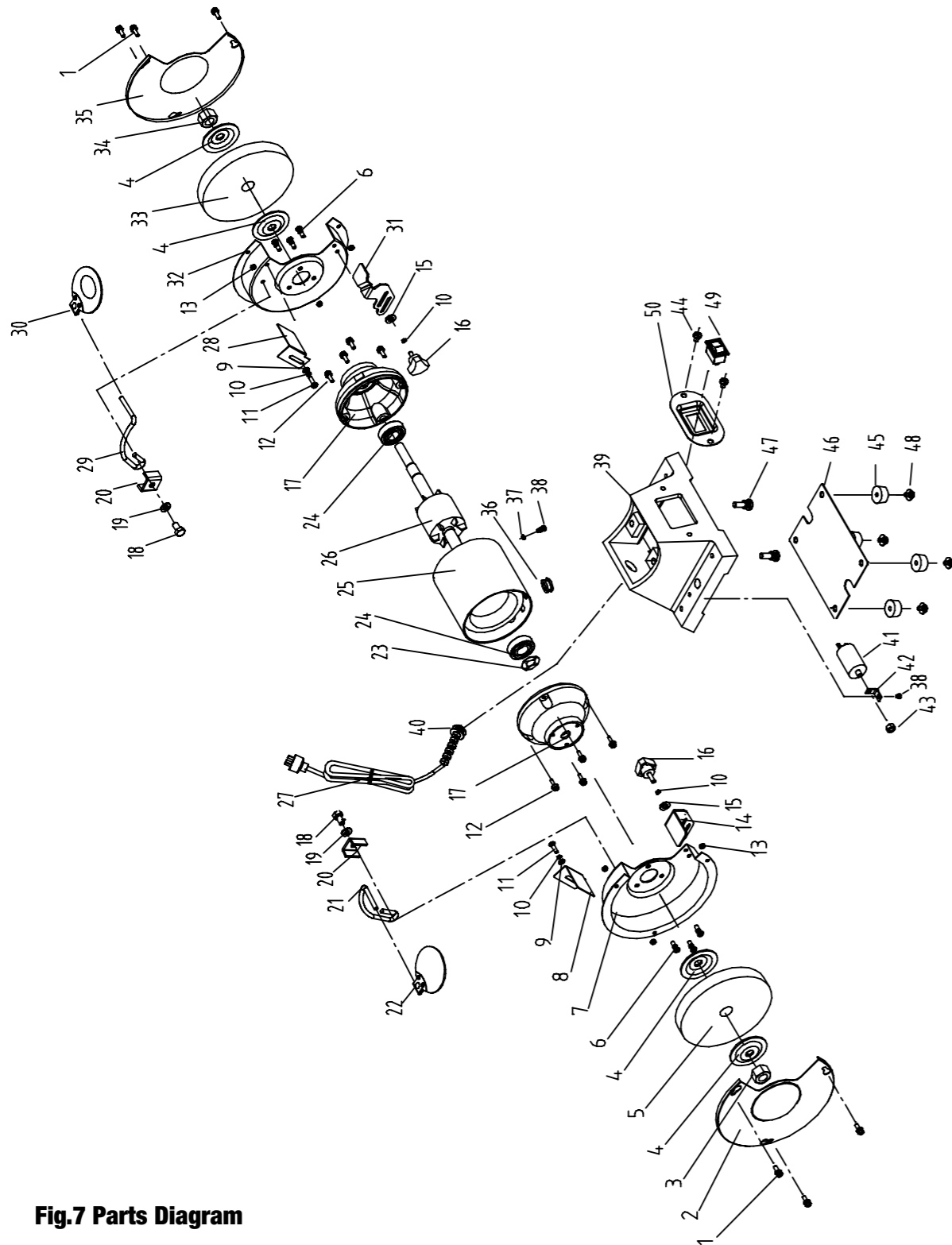

Fig.7 Parts Diagram

10. Parts List

No.	Specification		Qty
1	Philips Screw + Spring Washer + Flat Washer Assy	M5x18	6
2	Left Guard Cover		1
3	I Type Hex Nut	M16	1
4	Wheel Flange		4
5	Wheel (36#)		1
6	Philips Screw	M5x10	6
7	Left Guard Inner Cover		1
8	Left Spark Deflector		1
9	Flat Washer	D5	2
10	Spring Washer	D5	4
11	Philips Screw	M5x8	4
12	Philips Screw + Spring Washer Assy	M5x20	8
13	Lock Nut	M5	6
14	Left Work Rest		1
15	Big Flat Washer	D5	2
16	Lock Knob	M5x10	2
17	End Cap		2
18	Hex Nut	M6x14	2
19	Flat Washer	D6	2
20	Lock Block		2
21	Left Eyeshield Mount Rod		1
22	Eyeshield Assy		2
23	Flat Washer	D40	1
24	Bearing		2
25	Stator		1
26	Rotor		1
27	Wire With Plug		1
28	Right Spark Deflector		1
29	Right Eyeshield Mount Rod		1
30	Eyeshield With Magnifier Assy		1
31	Right Work Rest		1
32	Right Guard Inner Cover		1
33	Wheel (60#)		1
34	I Type Hex Nut	M16	1
35	Right Guard Cover		1
36	Cord Bushing		1

No.	Specification		Qty
37	Toothed Locking Washer		1
38	Philips Screw + Spring Washer Assy	M4x8	2
39	Base		1
40	Strain Relief		1
41	Capacitor		1
42	Capacitor Stand		1
43	Nut	M8	1
44	Philips Screw	M5x 8	2
45	Rubber Foot		4
46	Base Plate		1
47	Hex Bolt + Spring Washer Assy	M8x 22	2
48	Philips Screw + Big Flat Washer Assy	M5x 16	4
49	Switch		1
50	Switch Plate		1

Declaration of Conformity

Manufacturer: Jefferson Tools & Equipment

Address:

Jefferson Tools,
Herons Way,
Chester Business Park,
Chester
United Kingdom
CH49 QR

Manufacturers Responsible Representative:

Stephen McIntyre
(Operations Director)

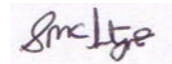

Date: 08/01/2010

Telephone: +44 (0)1244 646 048

Fax: +44 (0)1244 241 191

Email: enquiries@jeffersonstools.com

We declare that the models listed below conform with the directives and standards listed below:

JEFBGS06	150mm Bench Grinder
JEFBGS08	200mm Bench Grinder
JEFBGS06WL	150mm Bench Grinder with Work Light

- EC Machinery Directive (2006/42/EC)
- EC Low Voltage Directive (2006/95 EC)
- EC Electromagnetic Directive(2004/108 EEC)

Warning:

Please read all safety instructions carefully before use to avoid the risk of accident or personal injury.



Jefferson Tools, Herons Way, Chester Business Park, Chester, United Kingdom, CH4 9QR

Tel. +44 (0)1244 646 048

Email: sales@jeffersonstools.com

www.jeffersonstools.com